

Industrial Inverter

(For 3-phase motors)

Quick Start Manual

High-performance inverter

TOSVERT™ VF-AS3

3-phase 500V class 1.5 to 75kW
3-phase 600V (575V) class 2 to 100 HP
3-phase 690V class 2.2 to 90kW

Note

1. Make sure that this instruction manual is delivered to the end user of the inverter unit.
2. Read this manual before installing or operating the inverter unit, and store it in a safe place for reference.

Safety precautions

I

Introduction

II

Contents

Read first

1

Installation and wiring

2

Measures to satisfy standards

3

Selection and installation of peripheral devices

4

Table of parameters

5

Specifications

6

Warranty

7

Others

8

Toshiba Industrial Products and Systems Corporation



NNZ62480-03

I

Safety precautions

I

II

1

2

3

4

5

6

7

8

The items described in the instruction manual and on the inverter itself are very important so that you can use safely the inverter, prevent injury to yourself and other people around you as well as to prevent damage to property in the area.



Thoroughly familiarize yourself with the symbols and indications shown below and then continue to read this manual and "VF-AS3 instruction manual" (E6582062). Make sure that you observe all warnings given.

"VF-AS3 instruction manual" (E6582062) is available via the internet at
"<https://www.toshiba-tips.co.jp/en/products/inverter/standard.html>".



A hard copy of this information may be ordered to Toshiba sales representative or your Toshiba distributor at the contact information on the back cover of this manual.



Explanation of markings

Marking	Meaning of marking
 WARNING	Indicates a hazardous situation that, if not avoided, could result in death or serious injury.
 CAUTION	Indicates a hazardous situation that, if not avoided, could result in minor or moderate injury.
NOTICE	Indicates information considered important but not hazard-related. It is used to address practices not related to physical injury.

Meanings of symbols

Symbol	Meaning of Symbol
	Indicates a prohibition (Do not do it). Detailed information on the prohibition is described in illustration and text in or near the symbol.
	Indicates a mandatory action that must be followed. Detailed information on the mandatory action is described in illustration and text in or near the symbol.
	Indicates a warning or caution. Detailed information on the warning or caution is described in illustration and text in or near the symbol.

■ Limits in purpose

Our inverters are designed to control the speeds of three-phase induction motors, interior permanent magnet synchronous motors (IPMSMs) and the surface permanent magnet synchronous motors (SPMSMs) for general industry.

Our inverters cannot drive a single-phase motor.







SAFETY PRECAUTIONS

- This product is an electronic component for general industrial uses in industrial application. It cannot be used for applications where may cause a significant public impact, such as power stations and railways, and for uses that will require special quality control or warranty. Neither is it applicable to equipment (for nuclear power, airplanes, aerospace, public transport, life support, surgeries and various safety and entertainment devices) to which the failure or malfunction of this product could pose a direct risk or threat to human life. If you wish to use the product for limited purposes and the product is understood to require no special quality control or warranty, please contact us before purchase to evaluate if the usage is applicable.
- Please ensure in advance that the product is appropriately placed and installed in your own device or system, fulfilling the intended purpose. The equipment designer or the customers who assembles the final product shall be held liable for the selection and application of the product. We are not responsible for how the product is incorporated into the final system design. When using the product, please systematically back up your data or safety devices so that any failure or malfunction of the product will not cause any significant accidents.
- Even if the product is found to be inapplicable for conditions above after purchasing or using the product, the product will remain inapplicable for such conditions.
- Do not use the product for any load other than with general industry three-phase induction motors, interior permanent magnet synchronous motors (IPMSMs) and the surface permanent magnet synchronous motors (SPMSMs).
- Please read the instruction manual carefully before installing or operating the product and use it properly.

■ Handling

I

WARNING



 Disassembly inhibited	<ul style="list-style-type: none"> • Never disassemble, modify or repair. This can result in electric shock, fire and other injury. Please call your Toshiba distributor for repairs.
 Prohibited	<ul style="list-style-type: none"> • Never remove the front cover and the front small cover when the power is on or while charge lamp is on. The unit contains high voltage parts and contact with them will result in electric shock. • Do not stick your fingers into openings such as cable wiring holes and cooling fan covers. The unit contains high voltage parts and contact with them will result in electric shock or injury. • Do not place or insert any kind of object (electrical wire cuttings, rods, wires etc.) inside the inverter. This will cause a short circuit and result in electric shock or fire. • Do not allow water or any other fluids to come in contact with the inverter. This will cause a short circuit and result in electric shock or fire.
 Refer to manual	<ul style="list-style-type: none"> • Read the instruction manuals intended for use with this product before use, because operation of this product requires detailed installation and operation instructions provided in the instruction manuals. Otherwise it will result in electric shock, injuries or fire. The instruction manuals should be retained with this product at all times.
 Mandatory action	<ul style="list-style-type: none"> • Immediately turn the power off if the inverter begins to emit smoke, an unusual odor, or unusual sounds. Continuous use of the inverter in such a state will cause fire. If the inverter is left to be turned on in that state, it can cause fire. Please call your Toshiba distributor for repairs. • Always turn the power off if the inverter is not used for a long time. The inverter will have failure due to leakage current caused by dust and other material. If the inverter's power is left to be turned on in that state, it can cause fire.

CAUTION



 Contact inhibited	<ul style="list-style-type: none"> • Do not touch heat radiating fins or discharge resistors. These devices get high temperature, and you will get burned if you touch them. • Do not touch the edge of metal parts. Touching the sharp edge will result in the injury.
--	---

■ Transportation & installation

WARNING

 Prohibited	<ul style="list-style-type: none"> • Do not install and operate the inverter if it is damaged or any of its components is missing. This will result in electric shock or fire. Please call your Toshiba distributor for repairs. • Do not place any inflammable object near the inverter. If flame is emitted due to failure in the inverter, this will lead to fire. • Do not install the inverter in any location where the inverter could come into contact with water or other fluids. This will result in electric shock or fire.
 Mandatory action	<ul style="list-style-type: none"> • Install proper short-circuit protection device (eg. ELCB or fuse) between the power supply and the inverter (primary side). If proper short-circuit protection device is not installed, short circuit current cannot be shut down by inverter alone and it will result in fire. • An emergency stop device must be installed that is configured in accordance with the system specifications. If such an emergency stop device that can activate mechanical brake by shutting off power supply is not installed, operation cannot be stopped immediately by the inverter alone, thus resulting in an accident or injury. • In using a power distribution device and options for the inverter, they must be installed in a cabinet. When they are not installed in the cabinet, this will result in electric shock.

⚠ CAUTION

 Prohibited	<ul style="list-style-type: none"> • For transporting or carrying the inverter, do not hold by the front cover or top cover. The cover will come off and the unit will drop, resulting in injury. • Do not install the inverter in any place with large vibration. The unit will fall due to the vibration, resulting in injury. • Do not touch the edge of metal parts. Touching the sharp edge will result in the injury.
 Mandatory action	<ul style="list-style-type: none"> • Carry the inverter with the cover attached, and avoid holding or putting your hands in the wiring holes during the transportation. Otherwise, you can have your hands pinched and injured. • Carry the inverter by two people or more when the inverter is the model mass 20kg or more. If you carry the inverter alone, this will result in injury. • Transport a heavy load (ex. VFAS3-6300PC - 6750PC) by a crane. If you transport a heavy load by hand, this will result in injury. For lifting the inverter, hang the inverter with wire ropes via hanging bolts (hanging holes) provided at upper part of the inverter as shown in the figure. Note 1) Make sure that the inverter is hung by two wire ropes in a balanced manner, and be careful that the inverter does not receive excessive force during the hanging operation. Note 2) Be sure to carry the product with the cover attached. Note 3) Do not put your hand in the wiring port during transportation. • Mount the inverter on a metal plate. The rear panel will get high temperature. This will result in injury. • Install the inverter at a place which can support the unit's mass. If you install the inverter at a place which does not support the unit's mass, the unit will fall, resulting in injury. • Install a mechanical brake when it is necessary to hold a motor shaft. The brake function of the inverter cannot perform mechanical hold, and it will result in injury. • When ambient temperature is above 50°C, detach the operation panel from the inverter and mount it with door mounting kit at a location under 50°C or less. If using it under the temperature above 50°C, heat can rise up and flame can be emitted in the lithium battery inside the operation panel, that can result in fire.

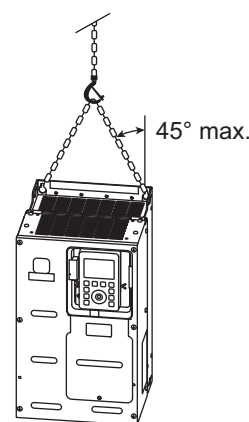



NOTICE

 Mandatory action	<ul style="list-style-type: none"> • Transport or install under the environmental conditions prescribed in the instruction manual. Transporting and installing under any other conditions will result in failure. • Transport the operation panel in accordance with law. Please transport the operation panel by airplane or ship in accordance with law as a lithium battery is used in the operation panel. • All options to be used must be those specified by Toshiba. The use of options other than those specified by Toshiba will result in an accident.
---	---

■ Wiring



WARNING

 Prohibited	<ul style="list-style-type: none"> • Do not connect power supply to the output (motor side) terminals [U/T1], [V/T2] and [W/T3]. Connecting power supply to the output will damage the inverter and result in fire. • Do not insert a braking resistor between DC terminals [PA/+] and [PC/-]. This will result in fire. Please connect the braking resistor in accordance with the instruction manual. • Do not touch wires of equipment (e.g. ELCB) that is connected to the inverter power side at least 15 minutes after turning off the power. If an electric charge remains in a capacitor in the inverter, touching the wires before the indicated time will result in electric shock. • Do not touch output terminals [U/T1], [V/T2] and [W/T3] on the PM motor side while the PM motor is rotating even after turning off the power. While the PM motor is rotating even after the power is turned off, as a high voltage is generated in the output terminals [U/T1], [V/T2] and [W/T3] on the PM motor side, touching the output terminals will result in electric shock. • Do not connect this inverter to power supply of corner-ground system. Connecting power supply of corner-ground system will damage the inverter and result in electric shock, fire and other injury. • When using this inverter with a power supply system that is grounded in other than the neutral point, the grounding capacitor should not be grounded (or the capacity of the grounding capacitor should not be increased). Otherwise, it will result in failure or fire.
 Mandatory action	<ul style="list-style-type: none"> • Electrical construction work must be done by a qualified expert. Erroneous connection of power supply by someone who does not have that expert knowledge will result in fire or electric shock. • Verify that the power is OFF before detaching the front cover and the front small cover. If you detach the front cover and the front small cover while the power is ON, this will result in electric shock or other injury. • The following steps must be performed before wiring. <ol style="list-style-type: none"> (1) Turn off all input power to the inverter. (2) Wait at least 15 minutes and check to make sure that the charge lamp is no longer lit. (3) Use a tester that can measure DC voltage 1400VDC or more, and check to make sure that the voltage to the DC main circuits (between PA/+ and PC/-) is 45V or less. If these steps are not properly performed, the wiring work will cause electric shock. • Wiring must be done after installation. If you perform wiring prior to installation, this will result in electric shock or other injury. • Install a protective device against earth leakage such as an earth leakage circuit breaker (ELCB) between the power supply and the inverter (primary side) into your system. If proper protection device against earth leakage is not installed, it can result in electric shock or fire. • Connect output terminals (motor side) correctly. If the phase sequence is incorrect, the motor will operate in reverse and that can result in injury. • Tighten the screws on the terminal block to specified torque. If the screws are not tightened sufficiently to the specified torque, this will result in fire. • Mount the front cover and the front small cover after wiring. If you turn the power on without mounting the front cover and the front small cover, this will result in electric shock or other injury. • Verify that the power supply voltage is within +10% and -15% of the rated voltage written on the name plate. If you do not use the appropriate power supply voltage, this will result in failure or fire.
 Be grounded	<ul style="list-style-type: none"> • The grounding wire must be connected securely. If the grounding wire is not securely connected, when the inverter has failure or earth leakage, this will result in electric shock or fire.

⚠ CAUTION



 Prohibited	<ul style="list-style-type: none"> • Do not install devices with built-in capacitors (such as noise reduction filters or surge absorbers) to the output terminals (motor side). Heat rises up and this can cause a fire. • Do not touch the edge of metal parts. Touching the sharp edge will result in the injury. • Do not pull the cable connected to the terminal blocks. This can cause terminal block damage or loose screw and can result in fire.
---	--

NOTICE



 Prohibited	<ul style="list-style-type: none"> • Do not detach the operation panel from the unit when the power is ON. This will result in failure. • When you connect a USB cable to the operation panel, do not perform the connection while the operation panel is attached to the unit. This will result in failure. • Do not connect Ethernet to the RS485 communication connector, nor connect RS485 communication to the Ethernet connector. Erroneous connection will result in failure. • Do not connect a capacitor with DC input terminal [PA/+], [PC/-] (including DC link with another inverter) without installing a proper pre-charge circuit. Excessive capacitance between DC terminals will cause the input overcurrent of the inverter and will result in product damage or failure.
 Mandatory action	<ul style="list-style-type: none"> • In case of DC link ([PA/+], [PC/-]) between the inverters, install protection device to prevent from excessive input current into an inverter. The excessive input current will result in product damage or failure.

■ Operations

WARNING

 Prohibited	<ul style="list-style-type: none"> • Never remove the front cover nor small cover when the power is on or while charge lamp is lit on front cover. The unit contains high voltage parts and contact with them will result in electric shock. • Do not touch terminals when the inverter's power is on even if the motor is stopped. Touching the terminals while voltage is applied will result in electric shock. • Do not touch switches when the hands are wet and do not try to clean the inverter with a damp cloth. This will result in electric shock. • Do not touch terminals or motor of the inverter while performing auto tuning. Touching the terminals or motor while voltage is applied to the terminals and motor can result in electric shock, even if the motor is stopped. After setting offline auto-tuning (F400 = "2"), execute the auto tuning at first start of the inverter. The auto tuning takes several seconds and the motor is stopped meanwhile, but voltage is applied to the terminals and motor. The motor may also generate a sound during the auto tuning, but this is not malfunction.
 Mandatory action	<ul style="list-style-type: none"> • Make sure to set the set-up menu or the parameter correctly. If you set the set-up menu or the parameter incorrectly, this will damage the inverter or cause the inverter to perform unexpected operation and can result in accident. When you set the parameter in the inverter via a parameter writer or operation panel, please transmit correct data. • Make sure that run commands are off before resetting the inverter after malfunction. If the inverter is reset while the run commands are on, the motor will restart suddenly, resulting in injury. • Install circuit protection such as the mechanical brake in the crane. If there is no sufficient circuit protection installed in the crane, insufficient motor torque while auto tuning will cause the machine stalling/falling. • Set the multi-rated settings correctly. Incorrectly setting the multi-rating rate can overheat the motor and can result in electric shock, fire and other injury. If you set 600V(575V) or 690V for a 500V motor, the motor will cause overvoltage during regeneration.

CAUTION

 Prohibited	<ul style="list-style-type: none"> • Do not use the motor or machine beyond its allowable operating range. Using the motor or machine beyond its allowable operating range will result in damage to motors and machines and injury. Please use motors and machines within their respective allowable operating ranges by referring to their respective instruction manuals.
 Mandatory action	<ul style="list-style-type: none"> • Use the inverter that conforms to specifications of the power supply and the three-phase motor to be operated. If you use the inappropriate inverter, not only will the three-phase motor not rotate correctly, but it will cause serious accidents such as overheating and burning out.

NOTICE



Mandatory
action

- Take countermeasures against leakage current (ex. reducing the carrier frequency or shortening the length of input/output power wires).
The leakage current through the stray capacitance of the input/output power wires of inverter and motor can affect peripheral devices.
- Operate under the environmental conditions prescribed in the instruction manual.
Operations under any other conditions will result in failure.
- Do not set the stall prevention level parameters (F601 and F185) extremely low.
If the stall prevention level parameters (F601 and F185) are set at or below the motor no-load current, the stall preventive function will be always enabled and increase the frequency when it judges that regenerative braking is taking place.
- Do not set the stall prevention level parameters (F601 and F185) at 30% or less under normal use conditions.

*Read the Safety precautions of "VF-AS3 instruction manual" (E6582062) for the information not mentioned here, such as maintenance, inspection and disposal.

II

Introduction

I

II

1

2

3

4

5

6

7

8

Thank you for purchasing Toshiba's industrial inverter.

To handle TOSVERT VF-AS3 correctly, this instruction manual explains how to install the inverter, refer to "VF-AS3 instruction manual" (E6582062) for how to wire control terminals of the inverter, operation procedure, how to run the motor, measures for protective functions (when an alarm/trip occurs) and etc.

Please be informed that the specifications described in the instruction manuals, technical data may be changed without notice.

■ Trademarks in this manual

- TOSVERT™ is a registered trademark of Kabushiki Kaisha Toshiba.
 - Microsoft® is a registered trademark of Microsoft Corporation.
 - Windows® is a registered trademark of Microsoft Corporation.
 - CANopen® is a registered trademark of CAN in AUTOMATION - International Users and Manufacturers Group e.V..
 - DeviceNet® is a registered trademark of ODVA, Inc..
 - EtherCAT® is a registered trademark of Beckhoff Automation GmbH.
 - Ethernet is a registered trademark of Fuji Xerox Co., Ltd..
 - EtherNet/IP™ is a trademark of ODVA, Inc..
 - Modbus is a registered trademark of SCHNEIDER ELECTRIC USA, INC..
 - PROFIBUS is a registered trademark of PROFIBUS Nutzerorganisation e.V..
 - PROFINET is a registered trademark of PROFIBUS Nutzerorganisation e.V..
 - QR Code® is a registered trademark of DENSO WAVE INCORPORATED.
-

Other product names appearing in this magazine may be used as trademarks by their respective companies.

Contents

I	Safety precautions	I-1
II	Introduction	II-1
1	Read first.....	1-1
	1. 1 Check product purchase	1-1
	1. 2 Indication of product type	1-4
	1. 3 Structure of equipment.....	1-7
	1. 3. 1 Outside view.....	1-7
	1. 3. 2 NEMA Type 1 kit	1-8
2	Installation and wiring.....	2-1
	2. 1 Installation	2-2
	2. 1. 1 Installation environment	2-2
	2. 1. 2 How to install	2-3
	2. 2 How to remove covers of inverter	2-8
	2. 2. 1 Charge lamp.....	2-9
	2. 2. 2 Front cover	2-9
	2. 3 Wiring	2-10
	2. 3. 1 Cautions for wiring.....	2-11
	2. 3. 2 Standard connection method	2-13
	2. 3. 3 Power terminals.....	2-20
	2. 3. 4 Switching of grounding capacitor	2-23
	2. 3. 5 Connect the control wiring and setup.....	2-25
	2. 4 Cautions for application.....	2-26
	2. 4. 1 Motor	2-26
3	Measures to satisfy standards	3-1
	3. 1 How to deal with CE marking.....	3-1
	3. 1. 1 Compliance with EMC Directive	3-1
	3. 1. 2 Compliance with Low Voltage Directive	3-5
	3. 1. 3 Compliance with safety standards.....	3-9
	3. 1. 4 Compliance with ATEX directive	3-9
	3. 1. 5 Declaration of Conformity.....	3-9
	3. 1. 6 Compliance of Ecodesign.....	3-9
	3. 2 Compliance with UL/CSA Standards	3-10
	3. 2. 1 General.....	3-10
	3. 2. 2 Compliance with Installation	3-11
	3. 2. 3 Compliance with Connection.....	3-12
	3. 2. 4 Cautions for peripheral devices.....	3-13
	3. 2. 5 Overload protection	3-16
	3. 2. 6 Motor thermal protection	3-16
	3. 2. 7 Motor integrated PTC thermal protection	3-16
	3. 2. 8 Other	3-16
4	Selection and installation of peripheral devices	4-1
	4. 1 Selection of wire size	4-1
	4. 2 Selection of a wiring device.....	4-6
	4. 2. 1 Selection table of a wiring device.....	4-6
	4. 2. 2 Installation of a molded-case circuit breaker (MCCB) and earth leakage circuit breaker (ELCB).....	4-11
	4. 2. 3 Installation of a magnetic contactor (MC).....	4-12
	4. 2. 4 Installation of a thermal relay (THR).....	4-13

4. 3 External option list.....	4-14
4. 4 Insert type option.....	4-14
5 Table of parameters	5-1
5. 1 Parameter setting.....	5-1
5. 2 Parameters different from standard specifications.....	5-3
5. 3 Parameter setting range, default setting depending on capacity, and minimum braking resistor values..	5-4
5. 4 Setup menu.....	5-11
5. 5 Multi-rating select.....	5-12
6 Specifications	6-1
6. 1 Model and main standard specification.....	6-1
6. 2 Outside dimensions and mass	6-17
7 Warranty.....	7-1
7. 1 Warranty period.....	7-1
7. 2 Scope of warranty	7-1
7. 3 Warranty exemptions	7-2
7. 4 Service after the end of production	7-2
8 Others	8-1

1

Read first

I

II

1

2

3

4

5

6

7

8

This chapter explains check items when you receive the inverter, names of parts of the inverter, and the flow of basic procedures before operation.

1.1 Check product purchase

CAUTION



Mandatory
action

- Use the inverter that conforms to specifications of the power supply and the three-phase motor to be operated.
If you use the inappropriate inverter, not only will the three-phase motor not rotate correctly, but it will cause serious accidents such as overheating and burning out.

Before using the product you have purchased, check to make sure that it is exactly what you ordered. Check the contents of accessories for damage.

Rating label

Applicable motor capacity

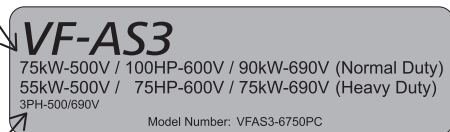

Rated voltage

* Refer to [1.2 ■ Multi-rating] for Normal Duty (ND rating) and Heavy Duty (HD rating).

Carton box

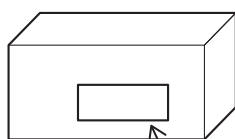

Type indication label

Danger/Warning label



Inverter main unit

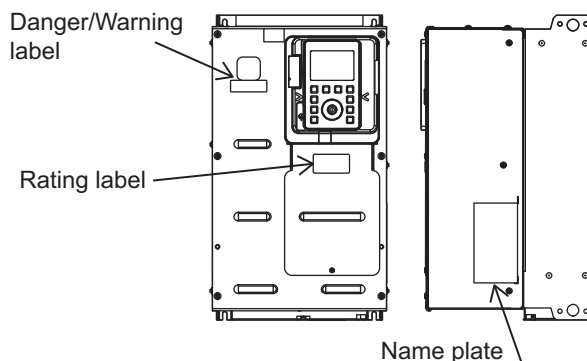

Name plate

TOSHIBA TRANSISTOR INVERTER
VFAS3-6750PC (12) ← Product revision

	INPUT		OUTPUT	
	ND	HD	ND	HD
U(V)	3PH 500/690	3PH 500/690	3PH 500/690	3PH 500/690
kW	50 / 60	50 / 60	0.01/590	0.01/590
HP	67.8 max 107 max	67.8 max 107 max	83	108
Loss	1.5 max (60/10%), Level IE2			
U(V)	3PH 500/600	3PH 575	3PH 575	3PH 575
FLA(%)	60	60	0.01/590	0.01/590
HP	71.9 max	92.6 max	FLA 77	FLA 99

SCCR: for rating and protection refer to User Manual
 Motor Overload Protection: Class 10
 Manufactured in India from foreign and domestic components
 Serial No. 5201190017210001(2)
 Applicable standard indication area
 Toshiba Industrial Products and Systems Corporation
 72-34,Horikawa-cho,Kawasaki,212-8585,Japan TSU



Important

- Keep original "DANGER" or "Warning" labels visibility on front cover for UL/CSA compliance.
- The input power supply for UL/CSA compliance is 500 to 600V - 50/60Hz.

Memo

- Product revision consists of numeric characters and an alphabet.

Instruction Manual

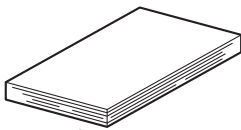

This manual

Warning label kit

Warning labels in 5 languages for sticking .

⚠️ WARNUNG

Gefahr von Verletzungen, elektrischem Schlag oder Brand.
 • Lesen Sie die Bedienungsanleitung.
 • Vor öffnen der Abdeckung Gerät vom Netz trennen und 15 Minuten warten.
 • Sorgen Sie für eine fachgerechte Erdung.

⚠️ AVVERTENZA

Rischio di lesioni, scosse elettriche o incendi.
 • Leggere le istruzioni del manuale.
 • Togliere tensione e attendere 15 minuti prima di aprire il coperchio.
 • Garantire un adeguato collegamento a terra.

⚠️ ADVERTENCIA

Riesgo de daños, descarga eléctrica o fuego.
 • Lea el manual de instrucciones.
 • Antes de retirar la cubierta corte la alimentación y espere 15 minutos.
 • Asegure una correcta conexión a tierra.

⚠️ 警告

有受傷、触电、发生火灾 灾的危险。
 • 请详细阅读使用说明书。
 • 在运行中或切断电源 15分钟之内，请勿揭开盖板。
 • 务必切实地进行接地。

⚠️ 警告

けが、感電、火災のおそれがあります。
 • 取扱説明書の注意事項を讀むこと。
 • 通電中及び電源遮断後15分以内は蓋子合カバーを開けないこと。
 • 確実に接地を行うこと。

SF
BF

MNS

BF

RUN
ERR

- German
- Italian
- Spanish
- Chinese
- Japanese

• Labels for communication option

Affix to lower side of communication indicator.



Important

- "VF-AS3 instruction manual" (E6582062) is available via the internet at "<https://www.toshiba-tips.co.jp/en/products/inverter/standard.html>".



1.2 Indication of product type

Explanation of the indication of the inverter type.

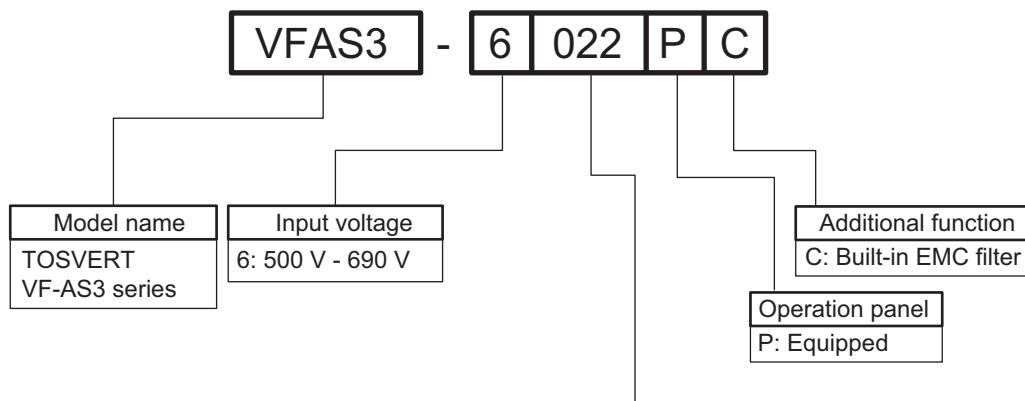

Applicable motor capacity of HD (for ND)			Note
500V class	600V(575V) class	690V class	
022: 1.5 kW (2.2 kW)	022: 2 HP (3 HP)	022: 2.2 kW (3 kW)	
030: 2.2 kW (3 kW)	030: 3 HP (-)	030: 3 kW (4 kW)	
040: 3 kW (4 kW)	040: - (5 HP)	040: 4 kW (5.5 kW)	
055: 4 kW (5.5 kW)	055: 5 HP (7.5 HP)	055: 5.5 kW (7.5 kW)	
075: 5.5 kW (7.5 kW)	075: 7.5 HP (10 HP)	075: 7.5 kW (11 kW)	
110: 7.5 kW (11 kW)	110: 10 HP (15 HP)	110: 11 kW (15 kW)	
150: 11 kW (15 kW)	150: 15 HP (20 HP)	150: 15 kW (18.5 kW)	
185: 15 kW (18.5 kW)	185: 20 HP (25 HP)	185: 18.5 kW (22 kW)	
220: 18.5 kW (22 kW)	220: 25 HP (30 HP)	220: 22 kW (30 kW)	
300: 22 kW (30 kW)	300: 30 HP (40 HP)	300: 30 kW (37 kW)	
370: 30 kW (37 kW)	370: 40 HP (50 HP)	370: 37 kW (45 kW)	
450: 37 kW (45 kW)	450: 50 HP (60 HP)	450: 45 kW (55 kW)	
550: 45 kW (55 kW)	550: 60 HP (75 HP)	550: 55 kW (75 kW)	
750: 55 kW (75 kW)	750: 75 HP (100 HP)	750: 75 kW (90 kW)	

Note) The code of applicable motor capacity is based on 690V class, HD rating.



Important

- This inverter has multi-rating. The motor capacity is described based on HD rating. In the case of ND rating, it is described with parentheses like (ND: **kW).



■ Initial setup

Make the initial settings according to the "INITIAL SETUP" sheet attached to the operation panel.

INITIAL SETUP

1. **Set a slide switch [SW1] to select Sink, Source logic or PLC**
Default setting makes STO activation ("PrA" into display), see the manuals in detail.
2. **Set a region after power on.**

	WARNING	Set a region correctly. If the setting is incorrect, the drive can have no work, some damages or unexpected movements.
---	----------------	---

	Display	Operation
	1: Japan 2: Mainly North America 3: Mainly Asia 4: Mainly Europe 5: China	Power on & Select a region.
	Init ↔ "Selected region"	Press OK or F4 key.
	0 . 0	Standby & Top view mode

Note) HD-600V (575V)-60Hz is set in default setting. For ND or 500V/690V motor use, before starting operation, please set parameter <AUL: Multi-rating select>.

Title	Parameter name	Adjustment range
AUL	Multi-rating select	2: ND – 600V (575V) – 60Hz 3: HD – 600V (575V) – 60Hz (Default) 14: ND – 500V – 50Hz 15: HD – 500V – 50Hz 16: ND – 690V – 50Hz 17: HD – 690V – 50Hz

Please set the date, time and language in the operation panel.
See the instruction manual in detail.

1

■ Multi-rating

WARNING



- Set the multi-rated settings correctly.
Incorrectly setting the multi-rating rate can overheat the motor and cause a malfunction or fire.

This inverter has multi-rating.

Select rating with the parameter <AUL: Multi-rating select> according to the characteristics of the load to be applied. The default setting is 600V(575V) and HD rating. For details, refer to "■ Type-Form, frame size, voltage class and HD/ND selection".

<AUL>="2, 14, 16: ND rating (120%-60s) (0 after execution)"

- Select it to apply equipment with variable torque characteristic.
- Example) Fans, pumps, blowers, etc.

<AUL>="3, 15, 17: HD rating (150%-60s) (0 after execution)"

- Select it to apply equipment with constant torque characteristic.
- Example) Conveyors, load transporting machinery, cranes, mixers, compressors, making machines, machine tools, etc.

Both of them return to "0" after setting.



Important

- If you set 600V(575V) or 690V for a 500V motor, the motor will overvoltage during regeneration. Set <AUL> correctly.

■ Type-Form, frame size, voltage class and HD/ND selection

This inverter has two types of units with frame size A1Y and A2Y according to the capacity. The following table shows the relationships between the types and the frame sizes.

HD-600V(575V)-60Hz is set in default setting. For ND or 500V/690V motor use, before starting operation, please set parameter <AUL: Multi-rating select>.

Type-Form	Voltage class	500V class		600V(575V) class		690V class	
	HD/ND	HD	ND	HD	ND	HD	ND
	<AUL> setting	15	14	3 (default)	2	17	16
	V/f setting	500V-50Hz		575V-60Hz		690V-50Hz	
	Frame size	Applicable motor capacity					
VFAS3-6022PC	A1Y	1.5 kW	2.2 kW	2 HP	3 HP	2.2 kW	3 kW
VFAS3-6030PC		2.2 kW	3 kW	3 HP	-	3 kW	4 kW
VFAS3-6040PC		3 kW	4 kW	-	5 HP	4 kW	5.5 kW
VFAS3-6055PC		4 kW	5.5 kW	5 HP	7.5 HP	5.5 kW	7.5 kW
VFAS3-6075PC		5.5 kW	7.5 kW	7.5 HP	10 HP	7.5 kW	11 kW
VFAS3-6110PC		7.5 kW	11 kW	10 HP	15 HP	11 kW	15 kW
VFAS3-6150PC		11 kW	15 kW	15 HP	20 HP	15 kW	18.5 kW
VFAS3-6185PC		15 kW	18.5 kW	20 HP	25 HP	18.5 kW	22 kW
VFAS3-6220PC		18.5 kW	22 kW	25 HP	30 HP	22 kW	30 kW
VFAS3-6300PC		22 kW	30 kW	30 HP	40 HP	30 kW	37 kW
VFAS3-6370PC	A2Y	30 kW	37 kW	40 HP	50 HP	37 kW	45 kW
VFAS3-6450PC		37 kW	45 kW	50 HP	60 HP	45 kW	55 kW
VFAS3-6550PC		45 kW	55 kW	60 HP	75 HP	55 kW	75 kW
VFAS3-6750PC		55 kW	75 kW	75 HP	100 HP	75 kW	90 kW

1

1.3 Structure of equipment

The following is brief explanation of the names and functions of parts that compose the inverter.

1.3.1 Outside view

This inverter has two types of units with frame size A1Y and A2Y according to the capacity. For details of outside dimensions, refer to [6. 2].

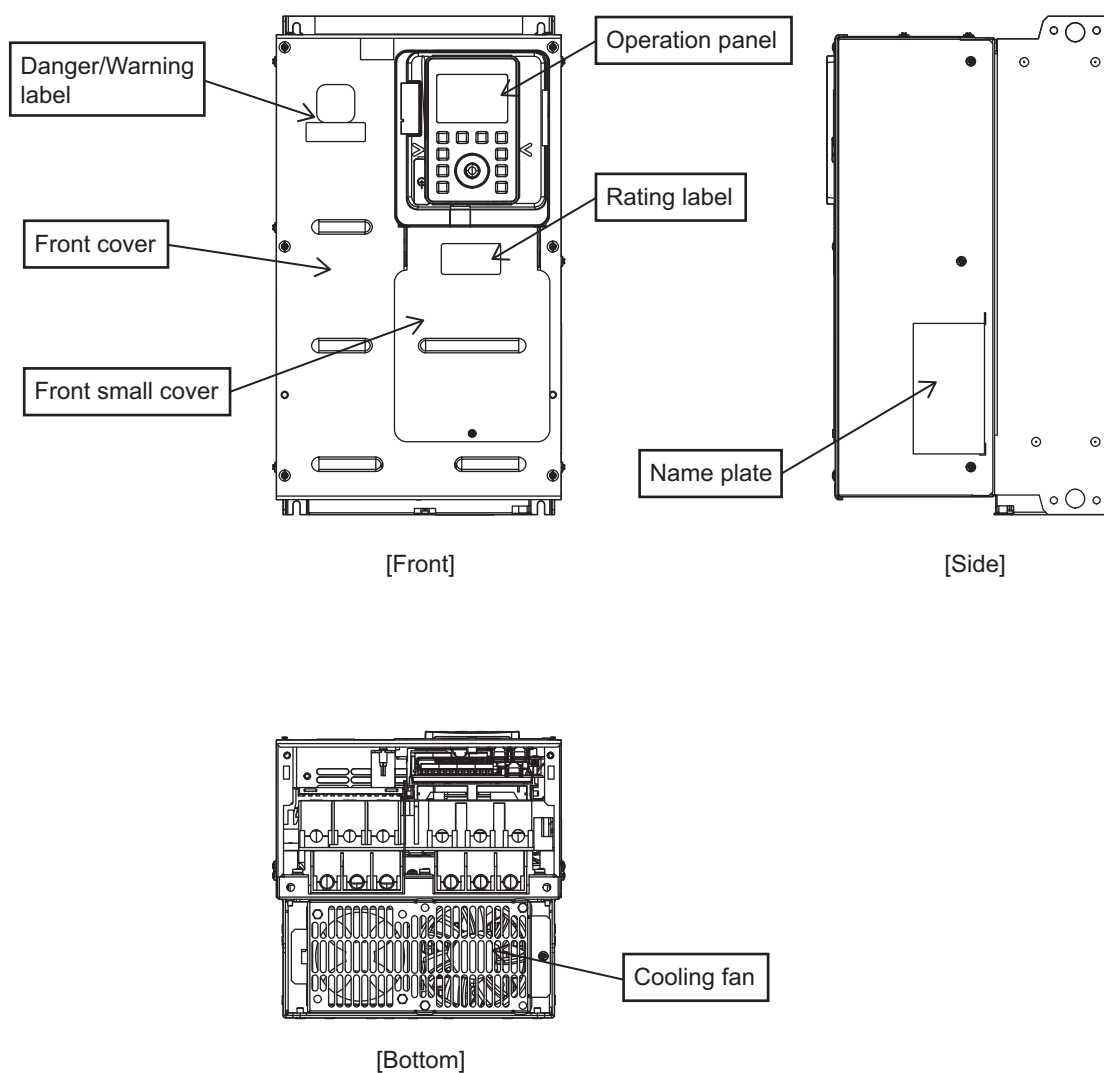

1.3.2 NEMA Type 1 kit

When you mount the VF-AS3 on a wall, you need the NEMA Type 1 kit (NEM301Z / NEM302Z) to comply with UL/CSA standard.

The kit includes top cover, conduit box and locknuts for cable gland.

For detail, refer to “NEMA Type 1 kit Instruction Manual” (E6582395).

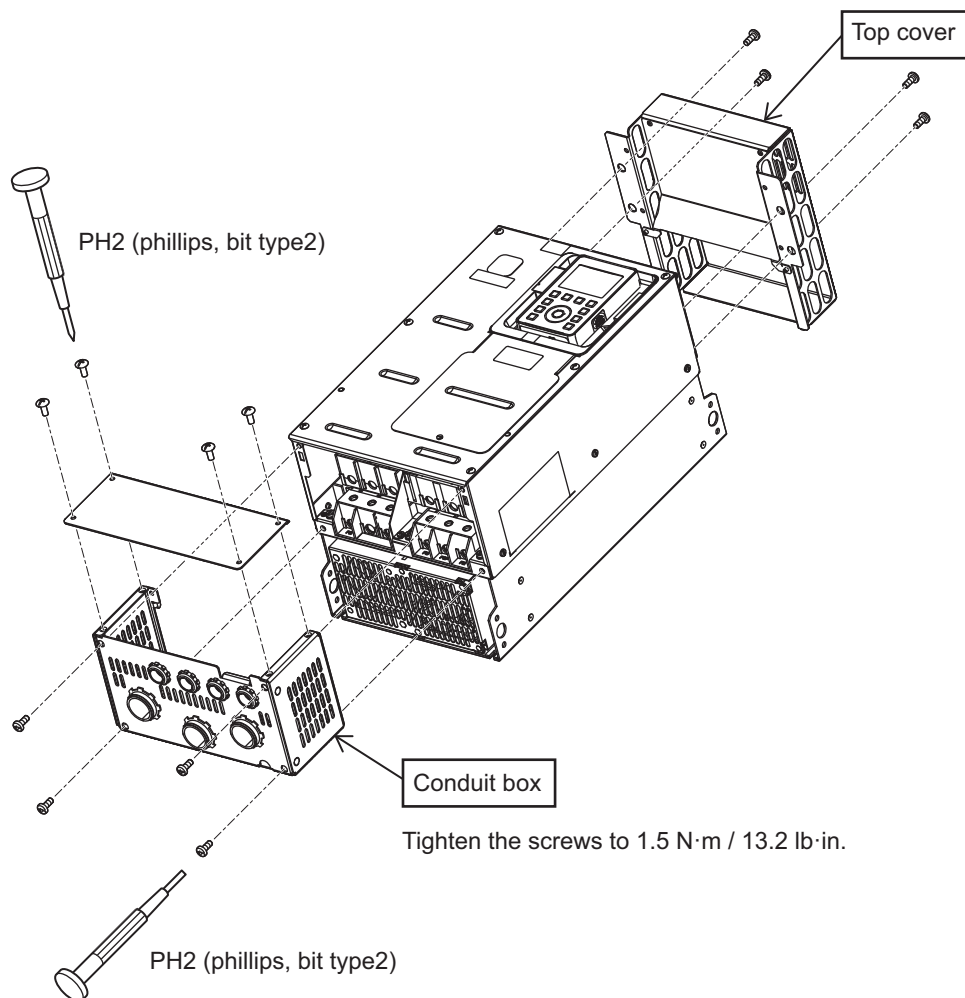
1

2

Installation and wiring

I

II

1

2

3

4



5

6



7

8

WARNING

 Disassembly prohibited	<ul style="list-style-type: none"> • Never disassemble, modify or repair. This can result in electric shock, fire and other injury. Please call your Toshiba distributor for repairs.
 Prohibited	<ul style="list-style-type: none"> • Do not stick your fingers into openings such as cable wiring holes and cooling fan covers. The unit contains high voltage parts and contact with them will result in electric shock or injury. • Do not place or insert any kind of object (electrical wire cuttings, rods, wires etc.) inside the inverter. This will cause a short circuit and result in electric shock or fire. • Do not allow water or any other fluids to come in contact with the inverter. This will cause a short circuit and result in electric shock or fire.
 Mandatory action	<ul style="list-style-type: none"> • Mount the inverter on a metal plate. The rear panel will get high temperature. • Install proper short-circuit protection device (eg. ELCB or fuse) between the power supply and the inverter (primary side). If proper short-circuit protection device is not installed, short circuit current cannot be shut down by inverter alone and it will result in fire. • An emergency stop device must be installed that is configured in accordance with the system specifications. If such an emergency stop device that can activate mechanical brake by shutting off power supply is not installed, operation cannot be stopped immediately by the inverter alone, thus resulting in an accident or injury. • The following steps must be performed before wiring and servicing. <ol style="list-style-type: none"> (1) Turn off all input power. (2) Wait at least fifteen minutes and check to make sure that the charge lamp is no longer lit. (3) Use a tester that can measure DC voltage (1400VDC or more), and check to make sure that the voltage to the DC power circuits (across PA/+ and PC/-) is 45V or less. If these steps are not properly performed, the wiring will cause electric shock.

CAUTION

 Prohibited	<ul style="list-style-type: none"> • For transporting or carrying the inverter, do not hold by the front cover. The cover will come off and the unit will drop, resulting in injury.
 Mandatory action	<ul style="list-style-type: none"> • Carry the inverter by two people or more when the inverter is the model mass 20kg or more (VFAS3-6022PC - 6220PC). If you carry the inverter alone, this will result in injury. • Transport a large-capacity inverter (VFAS3-6300PC - 6750PC) by a crane. If you transport a heavy load by hand, this will result in injury. • Install the inverter at a place which can support the unit's mass. If you install the inverter at a place which does not support the unit's mass, the unit will fall, resulting in injury.

NOTICE



Prohibited

- Do not pull the cable connected to the terminal blocks. This can result in damage or malfunction.

This chapter explains installation of the inverter, how to remove the covers, how to wire to the power supply and the motor, connection of the control circuit, and functions of terminals and connectors for communication.

2

2.1 Installation

Take special care with the installation environment of inverter. Install the inverter in a location that secures space for ventilation and heat emitting (in the cabinet, etc.), considering heat generation and occurrence of noise.

2.1.1 Installation environment



WARNING



Prohibited

- Do not place any inflammable object near the inverter. If flame is emitted due to failure in the inverter, this will lead to fire.
- Do not install the inverter in any location where the inverter could come into contact with water or other fluids. This will result in electric shock or fire.



Mandatory action

- Transport or install under the environmental conditions prescribed in the instruction manual. Transporting and installing under any other conditions will result in failure.



CAUTION



Prohibited

- Do not install the inverter in any place with large vibration. The unit will fall due to the vibration, resulting in injury.

This inverter is an electronic control instrument. Take full consideration to install it in the proper operating environment as follows.



■ Installation environment

- (1) Do not install in any location of high temperature, high humidity, moisture condensation and freezing and avoid locations where there is exposure to water and/or where there may be large amounts of dust, metallic fragments and oil mist.
- (2) Do not install in any location where corrosive gases or grinding fluids are present.
- (3) Operate in areas where ambient temperature ranges from -15°C to +60°C.
 - Where ambient temperature will rise above 50°C, derating of rated current is needed. Refer to "■ Current reduction curve" for details.
 - When using the inverter in locations with temperatures above 50°C, remove the operation panel of the inverter to use it.
- (4) Do not touch the heat sink as it may have a high temperature.
- (5) Do not install in any location subject to large amounts of vibration.



The details, refer to "VF-AS3 instruction manual" (E6582062).

2. 1. 2 How to install

WARNING

 Prohibited	<ul style="list-style-type: none"> • Do not install and operate the inverter if it is damaged or any of its components is missing. This will result in electric shock or fire. Please call your Toshiba distributor for repairs.
 Mandatory action	<ul style="list-style-type: none"> • Mount the inverter on a metal plate. The rear panel will get high temperature. Do not mount the inverter on an inflammable object, this will result in fire. • Install proper short-circuit protection device (eg. ELCB or fuse) between the power supply and the inverter (primary side). If proper short-circuit protection device is not installed, short circuit current cannot be shut down by inverter alone and it will result in electric shock or fire. • An emergency stop device must be installed that is configured in accordance with the system specifications. If such an emergency stop device that can activate mechanical brake by shutting off power supply is not installed, operation cannot be stopped immediately by the inverter alone, thus resulting in an accident or injury.

CAUTION

 Prohibited	<ul style="list-style-type: none"> For transporting or carrying the inverter, do not hold by the front cover. The cover will come off and the unit will drop, resulting in injury.
 Mandatory action	<ul style="list-style-type: none"> Carry the inverter by two people or more when the inverter is the model mass 20kg or more (VFAS3-6022PC - 6220PC). If you carry the inverter alone, this will result in injury. Carry a large-capacity inverter (VFAS3-6300PC - 6750PC) by a crane. If you carry a heavy load by hand, this will result in injury. Please take the utmost care for the operator's safety. Install the inverter at a place which can support the unit's mass. If you install the inverter at a place which does not support the unit's mass, the unit will fall, resulting in injury. Install a mechanical brake when it is necessary to hold a motor shaft. The brake function of the inverter cannot perform mechanical hold, and it will result in injury. When using an input filter (ex. harmonics reduction), make sure the inverter behavior with your equipment before use. Otherwise it can cause an accident by inverter instability due to resonance between the inverter and the input filter. When ambient temperature is above 50°C, use the operation panel by detaching it from the unit and install it on the location under the ambient temperature 50°C or less. If the operation panel is used under ambient temperature above 50°C, heat can rise up and flame can be emitted in the lithium battery used in the operation panel. All options to be used must be those specified by Toshiba. The use of options other than those specified by Toshiba will result in an accident.

Select an indoor location with good ventilation, and then install the inverter upright on a flat metal plate. For the positions and sizes of the mounting holes, refer to [6. 2].

■ If multiple inverters are installed

To install multiple inverters in one location, either normal basic installation or side-by-side installation (to align inverters side-by-side horizontally with no space) can be adopted. However, leave a space of 1 cm or more.

(a) Standard installation

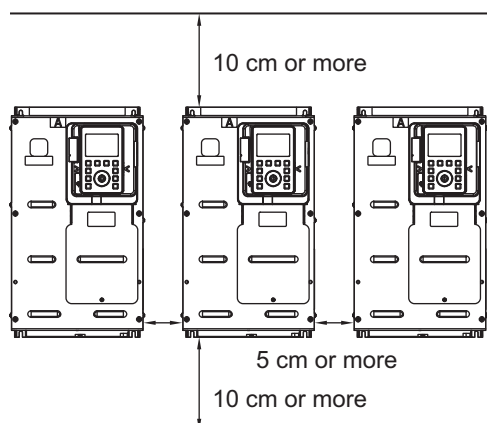

(b) Side-by-side installation

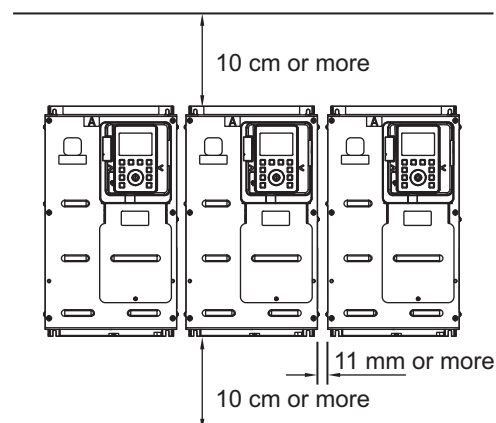

2

1) Basic installation

When installing multiple inverters, leave at least 5 cm or more of space between each inverter and install them aligned horizontally.

When using the inverter in locations with temperatures above 50°C, remove operation panel of the inverter to use it.

When using the inverter in locations with temperatures above 50°C, use the inverter with the output current reduced (refer to [■ Current reduction curve]).

2) Side-by-side installation

When side-by-side installing multiple inverters, leave at least 11 mm or more of space between each inverter and install them aligned horizontally.

When using the inverter in locations with temperatures above 50°C, remove operation panel of the inverter to use it.

When using the inverter in locations with temperatures above 50°C, use the inverter with the output current reduced (refer to [■ Current reduction curve]).

The space shown in the figure above is the minimum allowable space. Because the inverter has cooling fans built in on the top or bottom surfaces, make the space on top and bottom as large as possible to allow for air passage.



Important

- In case of the ambient temperature is above 50°C or side-by-side installation, the optional NEMA Type 1 kit can not be used.

■ Current reduction curve

Depending on the way in which the inverter is installed, the ambient temperature and the carrier frequency setting, you may need to reduce the inverter's continuous output current.

Reduction rates vary depending on the capacity. The capacities shown in these diagrams are capacities with the highest reduction rates. For the capacity of your inverter, refer to the [6. Specifications]. The table in [6. 1] lists current ratings at a carrier frequency of 2.5kHz.

The output current of 100% on the axis of ordinate corresponds to the output current at a carrier frequency of 2.5kHz and ambient air of 50°C.

Frame size: A1Y (VFAS3-6022PC to 6220PC)

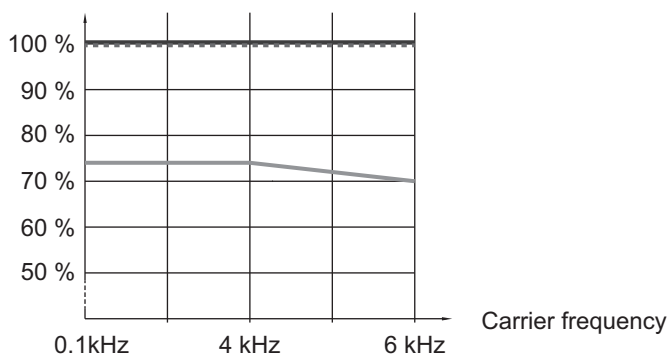

- 40°C (104 °F) - Standard installation, Side-by-side installation, with NEMA Type 1 kit
- 50°C (122 °F) - Standard installation, Side-by-side installation, with NEMA Type 1 kit
- 60°C (140 °F) - Standard installation, Side-by-side installation

Frame size: A2Y (VFAS3-6300PC to 6750PC)

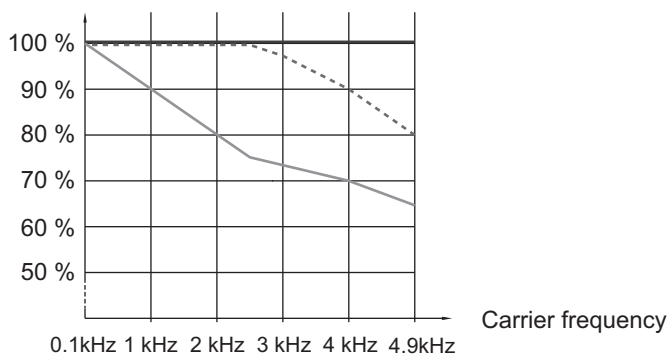

- 40°C (104 °F) - Standard installation, Side-by-side installation, with NEMA Type 1 kit
- 50°C (122 °F) - Standard installation, Side-by-side installation, with NEMA Type 1 kit
- 60°C (140 °F) - Standard installation, Side-by-side installation

■ Calorific values of inverter and required ventilation

The inverter will lose the power slightly as a result of conversion from AC to DC or from DC to AC. In order to suppress the rise in temperature inside the cabinet when this loss becomes heat loss, the interior of the cabinet must be ventilated and cooled.



The amount of forcible air-cooling ventilation required and the necessary heat discharge surface quantity when operating in a sealed cabinet depending on motor capacity are as follows.

Type-Form	Frame Size	Heavy Duty			Normal Duty		
		Inverter calorific value (W) *1	Forced air-cooled Required ventilation amount	Sealed cabinet Necessary heat discharge surface	Inverter calorific value (W) *1	Forced air-cooled Required ventilation amount	Sealed cabinet Necessary heat discharge surface
		(W)	(m ³ /min)	(m ²)	(W)	(m ³ /min)	(m ²)
VFAS3-6022PC	A1Y	111	0.63	2.22	128	0.73	2.56
VFAS3-6030PC	A1Y	128	0.73	2.56	146	0.83	2.92
VFAS3-6040PC	A1Y	146	0.83	2.92	174	0.99	3.48
VFAS3-6055PC	A1Y	174	0.99	3.48	211	1.20	4.22
VFAS3-6075PC	A1Y	211	1.20	4.22	277	1.57	5.54
VFAS3-6110PC	A1Y	277	1.57	5.54	356	2.02	7.12
VFAS3-6150PC	A1Y	356	2.02	7.12	467	2.65	9.34
VFAS3-6185PC	A1Y	467	2.65	9.34	560	3.18	11.2
VFAS3-6220PC	A1Y	560	3.18	11.2	647	3.67	12.9
VFAS3-6300PC	A2Y	525	2.98	10.5	688	3.91	13.8
VFAS3-6370PC	A2Y	688	3.91	13.8	842	4.78	16.8
VFAS3-6450PC	A2Y	842	4.78	16.8	1,012	5.74	20.2
VFAS3-6550PC	A2Y	980	5.56	19.6	1,250	7.10	25.0
VFAS3-6750PC	A2Y	1,250	7.10	25.0	1,634	9.28	32.7

*1 Case of 100% load continuous operation. The heat loss for the optional external devices (input reactor, radio noise reduction filters, etc.) is not included in the calorific values in the table.

2.2 How to remove covers of inverter

WARNING

 Prohibited	<ul style="list-style-type: none"> Never remove the front cover and the front small cover when the power is on or while charge lamp is on. The unit contains high voltage parts and contact with them will result in electric shock.
 Mandatory action	<ul style="list-style-type: none"> The following steps must be performed before wiring. <ol style="list-style-type: none"> Turn off all input power to the inverter. Wait at least 15 minutes and check to make sure that the charge lamp is no longer lit. Use a tester that can measure DC voltage 1400VDC or more, and check to make sure that the voltage to the DC main circuits (between PA/+ and PC/-) is 45V or less.

CAUTION

 Mandatory action	<ul style="list-style-type: none"> When removing and mounting the front cover, the front small cover or the power terminal block with a screwdriver, be sure not to scratch your hand as these results in injury. Turn the power off when removing the front cover and the front small cover. If the power is on, it can result in electric shock or injury. After wiring is complete, be sure to mount the front cover and the front small cover. Otherwise, it can result in electric shock or fire.
--	---

In the following cases, covers of the inverter should be removed.

- Wiring of the power circuit (refer to [2. 3. 2 ■ Standard connection diagram])
- Wiring and slide switch of the control terminal block (refer to [2. 3. 5] of "VF-AS3 instruction manual" (E6582062))
- Switching of the grounding capacitor (refer to [2. 3. 4])
- Mounting of insert type options (refer to [10. 4] of "VF-AS3 instruction manual" (E6582062))
- Heat discharge measures in the case of high ambient temperature, etc. (refer to [2. 1. 2] of "VF-AS3 instruction manual" (E6582062))
- Side-by-side installation of multiple inverters, etc. (refer to [2. 1. 2])

2.2.1 Charge lamp

While the charge lamp is on (red), voltage is applied, or high voltage remains in the inverter.

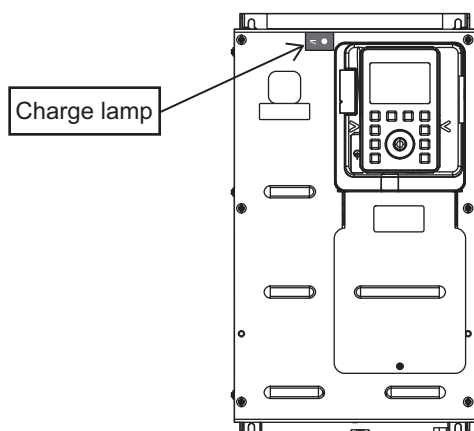
**2**

2.2.2 Front cover

- 1 Remove six screws of the front cover.
Store the removed screws so as not to be lost.

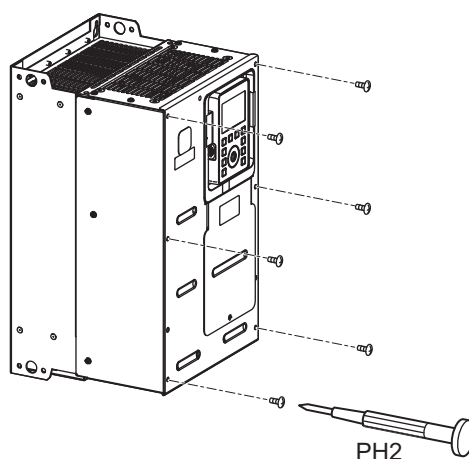

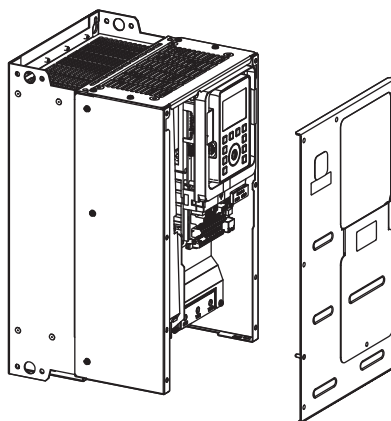

- 2 Lift the front cover and remove it from the unit.



- 3 Mount the front cover in the reverse procedure. Tighten the screws to 1.5 N·m / 13.2 lb·in.

2.3 Wiring

WARNING



 Disassembly prohibited	<ul style="list-style-type: none"> • Never disassemble, modify or repair. This can result in electric shock, fire and other injury. Please call your Toshiba distributor for repairs.
 Prohibited	<ul style="list-style-type: none"> • Do not stick your fingers into openings such as cable wiring holes and cooling fan covers. The unit contains high voltage parts and contact with them will result in electric shock or injury. • Do not place or insert any kind of object (electrical wire cuttings, rods, wires etc.) inside the inverter. This will cause a short circuit and result in electric shock or fire. • Do not allow water or any other fluids to come in contact with the inverter. This will cause a short circuit and result in electric shock or fire. • Do not connect this inverter to power supply of corner-ground system. Connecting power supply of corner-ground system will damage the inverter and result in fire. • When using this inverter with a power supply system that is grounded in other than the neutral point, the grounding capacitor should not be grounded (or the capacity of the grounding capacitor should not be increased). Otherwise, it will result in failure or fire. • When using this inverter with a power supply of IT system (power supply isolated from ground or grounded through high impedance), disconnect the grounding capacitor. If connecting grounding capacitor with power supply of IT system, it will result in failure or fire.
 Mandatory action	<ul style="list-style-type: none"> • All options to be used must be those specified by Toshiba. The use of options other than those specified by Toshiba will result in an accident. • In using a power distribution device and external options for the inverter, they must be installed in a cabinet. When they are not installed in the cabinet, this will result in electric shock.

This section explains cautions for wiring, how to connect to the power supply, motor, and control equipment, and how to switch the grounding capacitor, etc.

Regarding functions of the terminal blocks and communication ports, refer to [2. 3] of "VF-AS3 instruction manual" (E6582062).

2.3.1 Cautions for wiring

WARNING

 Prohibited	<ul style="list-style-type: none"> • Never remove the front cover and the front small cover when the power is on or while charge lamp is on. The unit contains high voltage parts and contact with them will result in electric shock. • The following steps must be performed before wiring. <ol style="list-style-type: none"> (1) Turn off all input power to the inverter. (2) Wait at least 15 minutes and check to make sure that the charge lamp is no longer lit. (3) Use a tester that can measure DC voltage 1400VDC or more, and check to make sure that the voltage to the DC main circuits (between PA/+ and PC/-) is 45V or less. If these steps are not properly performed, the wiring will cause electric shock.
 Mandatory action	<ul style="list-style-type: none"> • Electrical construction work must be done by a qualified expert. Erroneous connection of power supply by someone who does not have that expert knowledge will result in fire or electric shock. • Connect output terminals (motor side) correctly. If the phase sequence is incorrect, the motor will operate in reverse and that can result in injury. • Wiring must be done after installation. If you perform wiring prior to installation, this will result in electric shock or other injury. • Verify that the power is turned off and the charge lamp is off before starting wiring. If you perform wiring without verification, this will result in electric shock. • Tighten the screws on the terminal block to specified torque. If the screws are not tightened sufficiently to the specified torque, this will result in fire. • Mount the front cover and the front small cover after wiring. If you turn the power on without attaching the front cover and the front small cover, this will result in electric shock or other injury. • Verify that the power supply voltage is within +10% and -15% of the rated voltage written on the name plate. If you do not use the appropriate power supply voltage, this will result in failure or fire.
 Be grounded	<ul style="list-style-type: none"> • The grounding wire must be connected securely. If the grounding wire is not securely connected, when the inverter has failure or earth leakage, this will result in electric shock or fire.

CAUTION

 Prohibited	<ul style="list-style-type: none"> • Do not attach devices with built-in capacitors (such as noise reduction filters or surge absorbers) to the output terminals (motor side). Heat rises up and this could cause a fire.
---	--

Pay attention to the following when wiring.

■ Measures for noise

To prevent electrical interference due to high-frequency noise generated by the inverter, separately bundle wires to the power circuit's power side terminals ([R/L1], [S/L2], [T/L3]) and wires to the motor side terminals ([U/T1], [V/T2], [W/T3]).

■ Control power supply

The control power of this inverter is supplied internally from the power circuit power supply. Therefore, if a malfunction or trip causes the power circuit to be shut off, control power will also be shut off.

- To check the cause of the malfunction or the cause of the trip when turning on the power again, set <F602: Trip record retention> to "1: Retain at power off".
- To make the control circuit continuously operate even if the power circuit is shut off due to malfunction or tripping, use a control power supply unit and supply the power to the control circuit.

■ Wiring

- For power terminals, use ferrules with insulation sleeve terminal. Connect the terminals so that adjacent terminals do not touch each other.
- For the sizes of electric wires used in the power circuit, refer to the table in [4. 1].
- The length of each wire is assumed to be 30 m or less. If the wire length is over 30 m, the wire size (diameter) must be increased.
- For grounding terminal, use wires of the size that is equivalent to or larger than those given in table [4. 1] and always ground the inverter.
- Wire the grounding wire as close as possible to the inverter.
- To ground the inverter unit, connect it to an exclusive grounding terminal. Do not use screws of the case, chassis, etc.
- Tighten the screws of the power terminal block to the recommended tightening torque shown in the table [2. 3. 3].
- Tighten the screws of the control terminal block to the recommended tightening torque, refer to [2. 3. 5] of "VF-AS3 instruction manual" (E6582062).

■ Magnetic contactor, relay

To use a magnetic contactor or a relay, be sure to connect a surge absorber to the exciting coil. To incorporate a VF-AS3 into another cabinet, connect surge absorbers to other magnetic contactors and relays in the same cabinet. In this case, select surge absorbers according to the relay capacity.



Connect surge absorbers as close to the magnetic contactor as possible.

■ Control terminals

Refer to "VF-AS3 instruction manual" (E6582062).

2.3.2 Standard connection method

⚠ WARNING

 Prohibited	<ul style="list-style-type: none"> Do not connect power supply to the output (motor side) terminals [U/T1], [V/T2] and [W/T3]. Connecting power supply to the output will damage the inverter and result in fire. Do not insert a braking resistor between DC terminals [PA/+] and [PC/-]. This will result in fire. Please connect the braking resistor in accordance with the instruction manual. Do not touch wires of equipment (e.g. ELCB) that is connected to the inverter power side at least 15 minutes after turning off the power. If an electric charge remains in a capacitor in the inverter, touching the wires before the indicated time will result in electric shock.
 Be grounded	<ul style="list-style-type: none"> The grounding wire must be connected securely. If the grounding wire is not securely connected, when the inverter has failure or earth leakage, this will result in electric shock or fire.

2

The wiring of the power supply and motor is connected to the power terminal block and the wiring of external control equipment such as control signals to the control terminal block.

■ Connection to power supply and motor

This diagram shows a standard wiring of the power circuit.

Connection to the power supply and motor wiring is common to all the types.

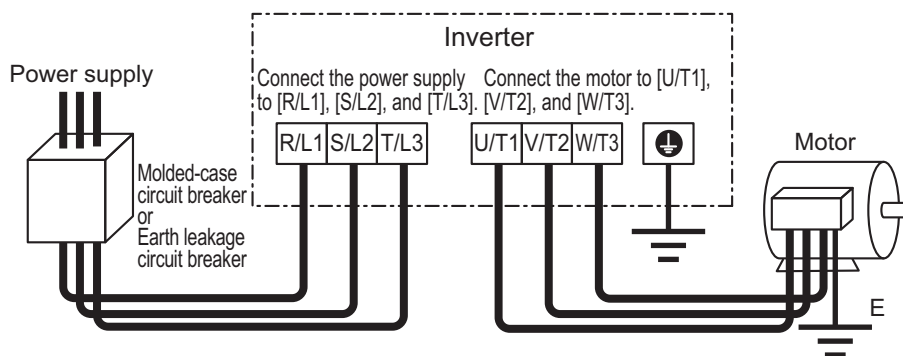

■ Connection to peripheral devices

This diagram shows an example of connection to peripheral devices.

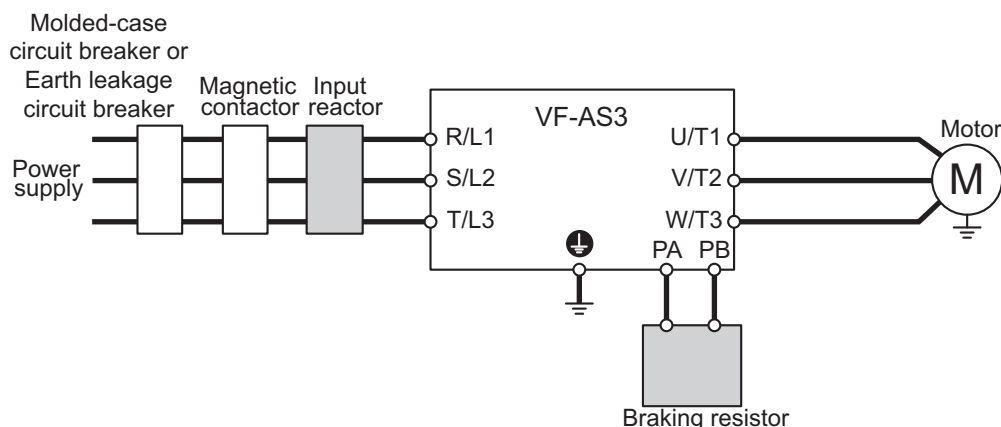

For detail instruction of wiring, refer to [2. 3. 2] of "VF-AS3 instruction manual" (E6582062).

■ Connection procedure of power circuit wiring

The procedure for connecting the main circuit wiring is described below using the frame size A1Y with NEMA Type 1 kit as an example.

Connect other sizes in the same way.

- 1 Remove the front cover.
Refer to [2. 2] for removal.
- 2 Loosen the screws of the grounding terminal for inverter case. Mount the grounding wire to the screws of grounding terminal. Switch the grounding capacitor if necessary. For details of how to switch, refer to [2. 3. 4].

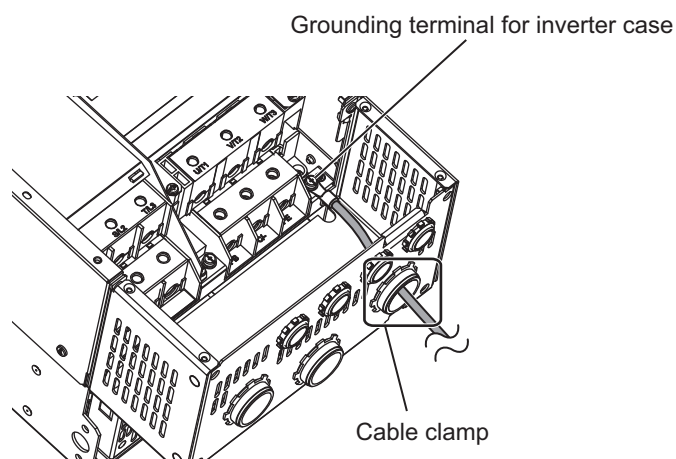

Frame size A1Y
Screw size: M5
Tightening torque: 2.6 N·m (23 lb·in)

Frame size A2Y
Screw size: M8
Tightening torque: 11.8 N·m (104 lb·in)

- 3 Loosen the [U/T1], [V/T2], [W/T3], and [PE] terminal screws on the main circuit terminal block.

- 4 Attach the grounding wire to [PE] terminal.

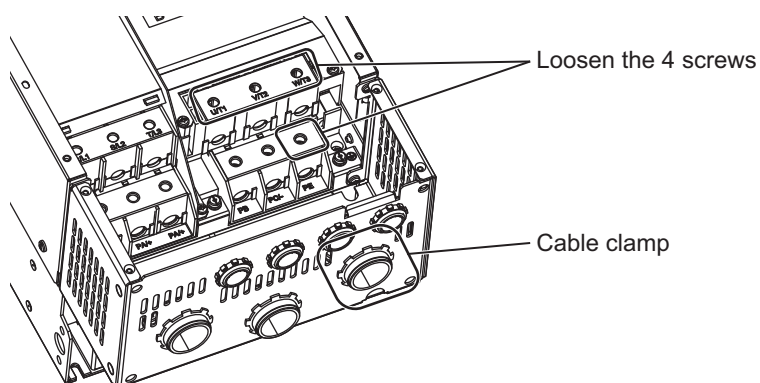

- 5 Thread the motor wiring through the cable clamp.
If using NEMA Type 1 kit, pass through cable clamp.
- 6 Attach each motor wire to the corresponding terminal screw.
Please process the end of each motor wiring beforehand refer to [4. 1 Selection of wire size] for terminal torque and wire strip length is 32 mm.

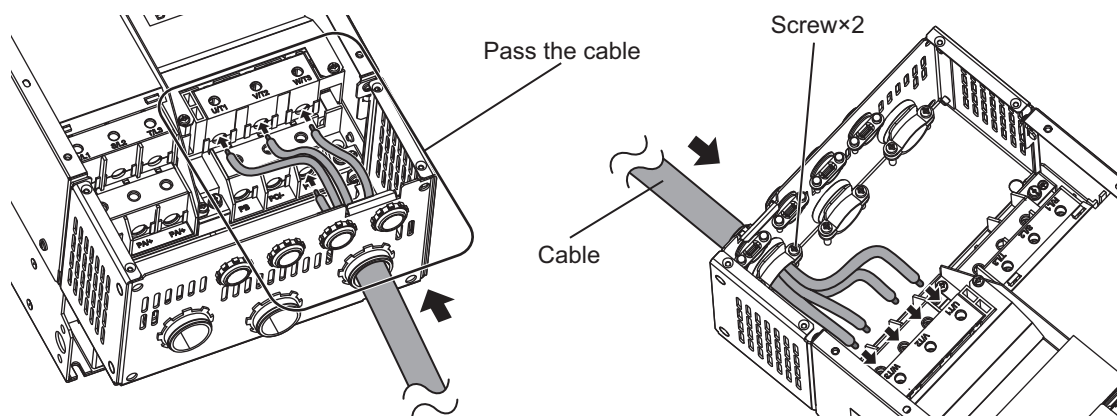

- 7 Tighten the [U/T1], [V/T2], [W/T3] and [PE] terminal screws.
Refer to [4. 1 Selection of wire size] for terminal torque and wire strip length is 32 mm.
- 8 Tighten the screw × 2 of the cable clamp and fix the motor wiring (4 pieces) with the cable clamp.

- 9 Similarly, pass the power cable through another cable clamp, and then attach it to the [R/L1], [S/L2], [T/L3] and [PE] terminals.
Refer to [4. 1 Selection of wire size] for terminal torque and wire strip length is 32 mm.
The power supply wiring is also fixed with a cable clamp.

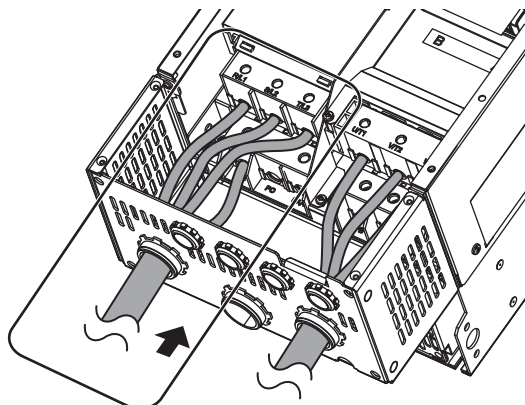

- 10 When connection is complete, mount the front cover.
For how to mount, refer to [2. 2. 2].

Regarding control terminal connection, refer to [■ Standard connection diagram] and [2. 3. 5 Control terminals] of "VF-AS3 instruction manual" (E6582062).

■ Standard connection diagram

This diagram shows a standard wiring of the power circuit and control circuit.

[Standard connection diagram – sink logic with using internal supply]

This diagram shows an example of a standard connection.

Power supply

500V, 690V class *10

Three-phase 500 - 690 V - 50/60 Hz

600V(575V) class

Three-phase 500 - 600 V - 50/60 Hz

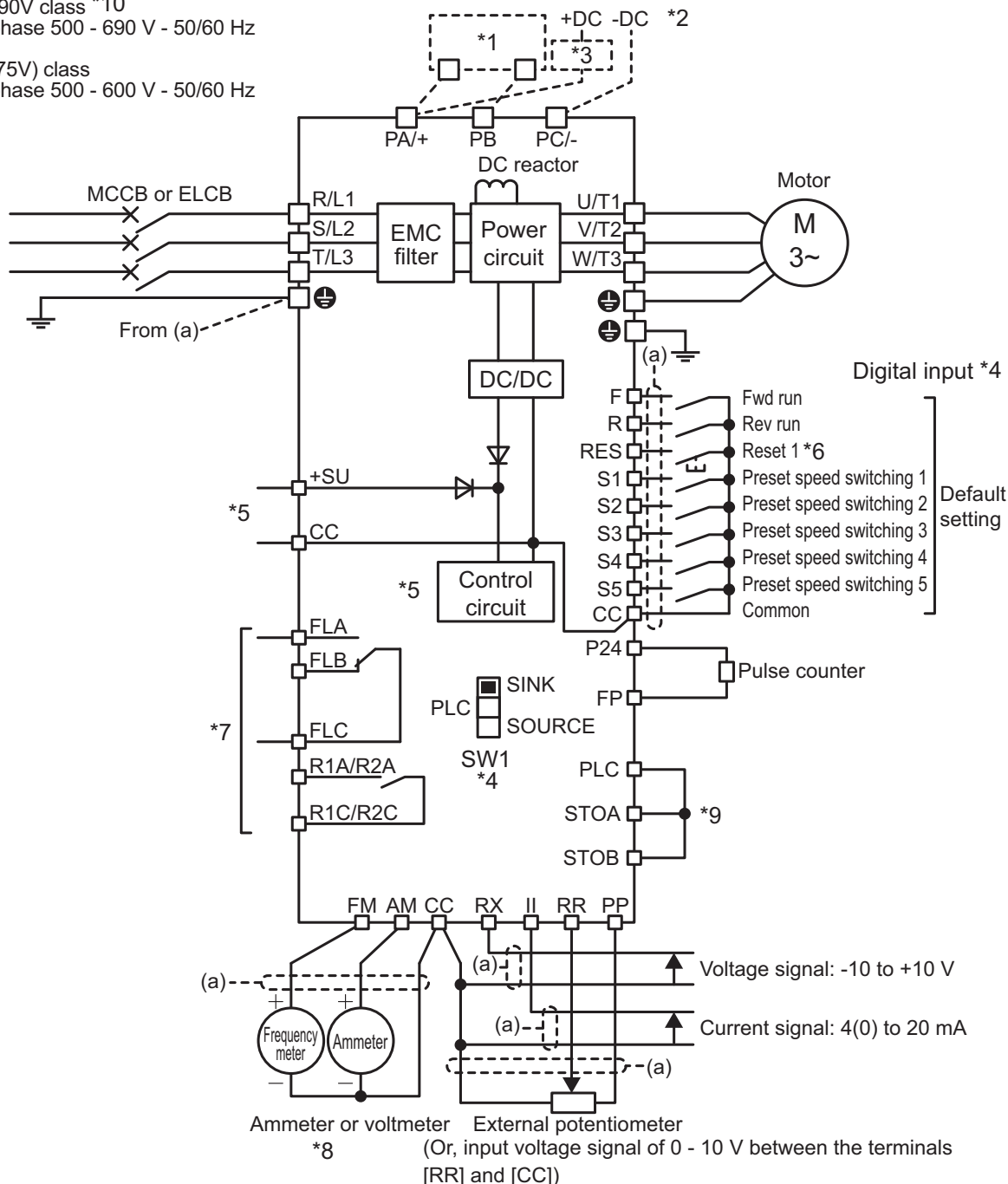

*1 External braking resistor (option).

*2 To supply DC power, connect the inverter between the terminals [PA/+] and [PC/-].

*3 In case of connecting a DC power supply, a circuit to suppress an inrush current is required. For detail, refer to application manual "DC power supply connect to inverter" (E6582156).

*4 This example shows "Sink" logic with using internal power supply. For use of external power supply, refer to [2. 3. 5] of "VF-AS3 instruction manual" (E6582062).

*5 To supply control power from an external power supply for backing up the control power supplied from the inverter, it needs DC power supply (24V-1A). In this case, it is used in conjunction with the inverter internal power supply.

-
- *6 The reset signal is activated by ON→OFF trigger input.
 - *7 Connect to power to comply with OVCII(overvoltage categoryII). Isolation transformer is necessary when connecting to power supply (OVCIII).
 - *8 Calibration is required when connecting a meter. Refer to [5. 2. 6] of "VF-AS3 instruction manual" (E6582062).
 - *9 This inverter has not applied for ATEX directive.
Therefore, [STOA] and [STOB] terminals can't use for ATEX directive.
 - *10 Set the <AUL: multi-rated setting> correctly, refer to the [1. 2]

[Standard connection diagram – source logic with using internal supply]

This diagram shows an example of a standard connection.

Power supply

500V, 690V class *10

Three-phase 500 - 690 V - 50/60 Hz

600V(575V) class

Three-phase 500 - 600 V - 50/60 Hz

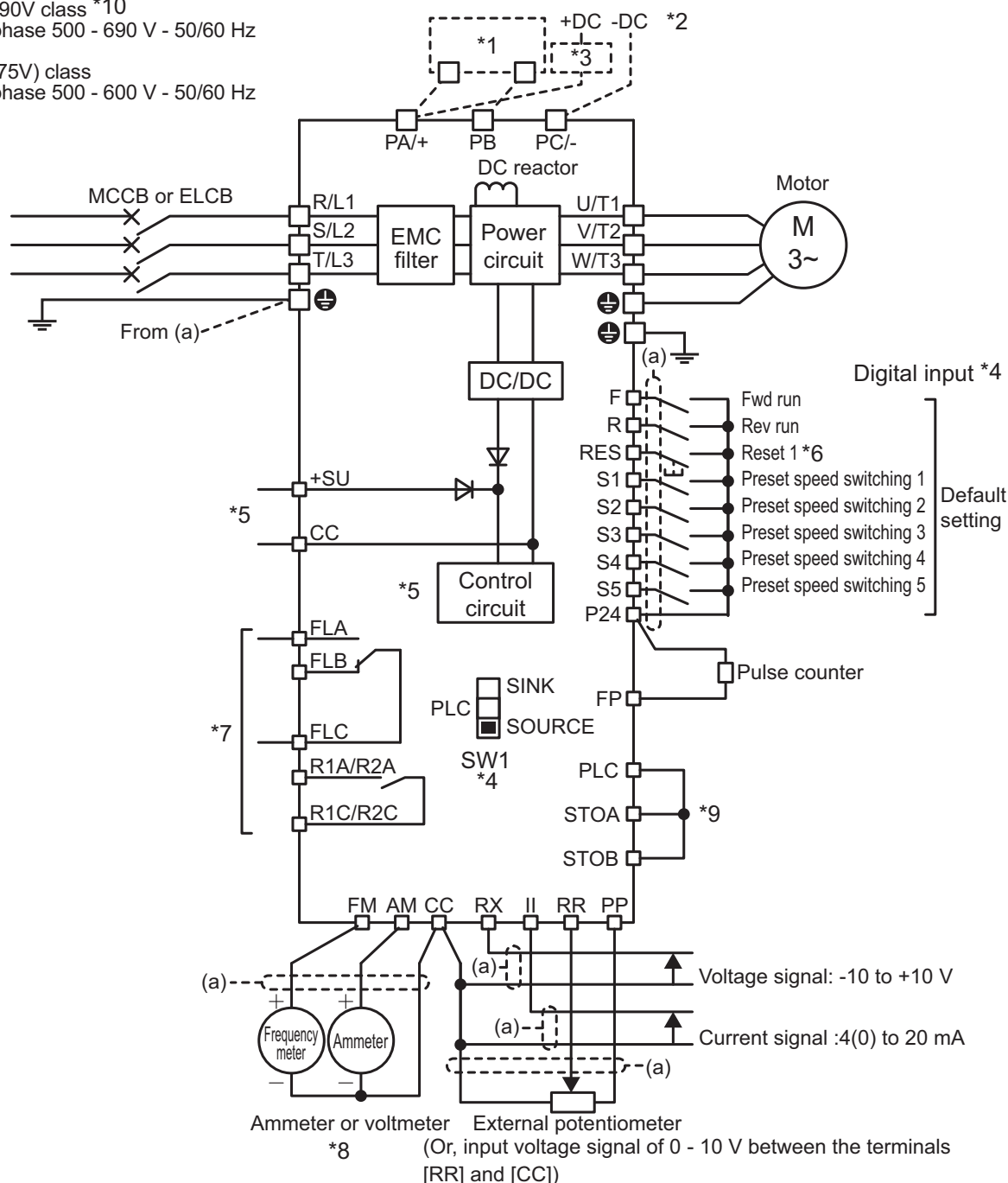

*1 External braking resistor (option).

*2 To supply DC power, connect the inverter between the terminals [PA/+] and [PC/-].

*3 In case of connecting a DC power supply, a circuit to suppress an inrush current is required. For detail, refer to application manual "DC power supply connect to inverter" (E6582156).

*4 This example shows "Source" logic with using internal power supply. For use of external power supply, refer to [2. 3. 5] of "VF-AS3 instruction manual" (E6582062).

*5 To supply control power from an external power supply for backing up the control power supplied from the inverter, it needs DC power supply (24V-1A). In this case, it is used in conjunction with the inverter internal power supply.

*6 The reset signal is activated by ON→OFF trigger input.

*7 Connect to power to comply with OVCII(overvoltage categoryII). Isolation transformer is necessary when connecting to power supply (OVCIII).

*8 Calibration is required when connecting a meter. Refer to [5. 2. 6] of "VF-AS3 instruction manual" (E6582062).

*9 This inverter has not applied for ATEX directive.

Therefore, [STOA] and [STOB] terminals can't use for ATEX directive.

*10 Set the <AUL: multi-rated setting> correctly, refer to the [1. 2].

2. 3. 3 Power terminals

Terminal symbol	Function	Applicable frame size
 [PE]	Grounding terminal for inverter case. There are multiple terminals in the product, they are also used to connect shield of input/motor cables.	All frame sizes
[R/L1] [S/L2] [T/L3]	Connected to an AC power supply. Three-phase 500 - 690 V - 50/60 Hz	All frame sizes
[U/T1] [V/T2] [W/T3]	Connected to a three-phase motor.	All frame sizes
[PA/+] [PB]	Connected to a braking resistor. Change the parameters <F304: Dynamic braking, OLr trip>, <F308: Braking resistance>, and <F309: Braking resistor capacity> if necessary.	All frame sizes
[PA/+] [PC/-]	A DC power can be supplied. For all models, a rush current suppression circuit (optional) is required.	All frame sizes

■ Arrangement of power terminals

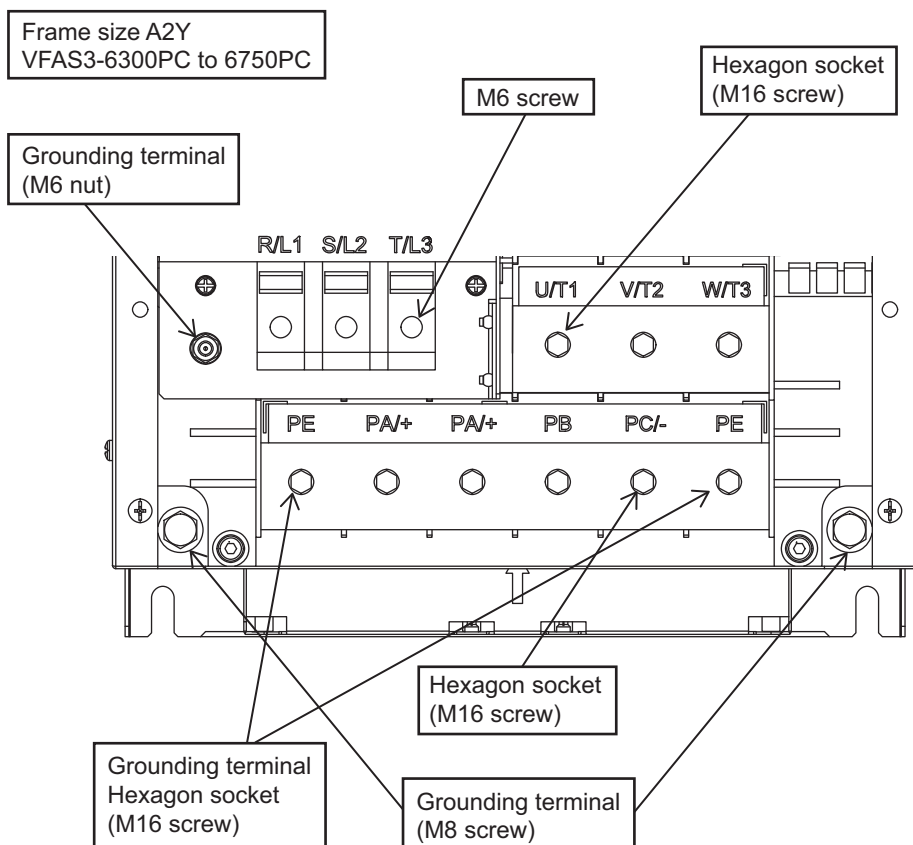
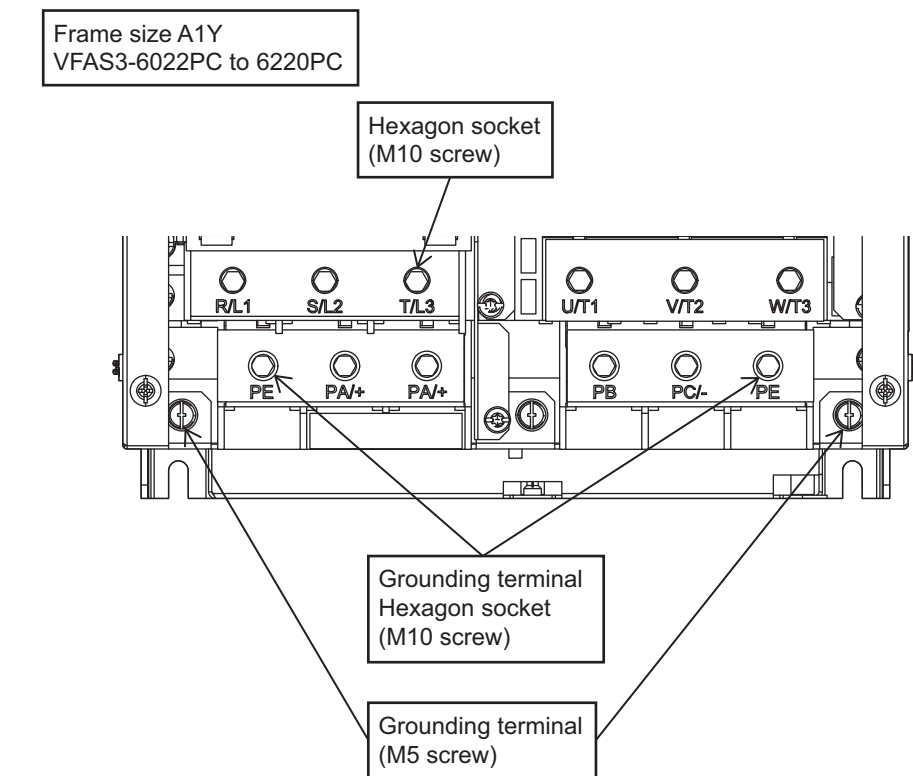

The wire strip length is 32 mm and the tightening torque depend on wire size. Refer to [4. 1 Selection of wire size].



Important



- After finishing the wiring installation, tighten all power terminal screws with proper torque again.

■ Grounding terminal (for inverter case) torque

Frame size	Type-Form	Screw size	Torque *1	
			(N·m)	(lb·in)
A1Y	VFAS3-6022PC to 6220PC	M5	2.6	23
A2Y	VFAS3-6300PC to 6750PC	M8	11.8	104

2. 3. 4 Switching of grounding capacitor

WARNING

 Prohibited	<ul style="list-style-type: none"> Do not connect this inverter to power supply of corner-ground system. Connecting power supply of corner-ground system will damage the inverter and result in fire. When using this inverter with a power supply system that is grounded in other than the neutral point, the grounding capacitor should not be grounded (or the capacity of the grounding capacitor should not be increased). Otherwise, it will result in failure or fire.
 Mandatory action	<ul style="list-style-type: none"> Make sure to turn the power off before switching the grounding capacitor. If not, it will result in electric shock.

This inverter has a built-in EMC noise filter and the inverter input power supply is grounded via the capacitor. By changing the capacity of the grounding capacitor to small, the leakage current through the inverter can be reduced. When your power supply system is IT system, change the capacity of the grounding capacitor to small. When the capacity of the grounding capacitor change to small, the inverter unit no longer comply with EMC directive.

It is switched by changing the position of the exclusive switching screw(s) or switch.

 Important	<ul style="list-style-type: none"> Note that when the capacity of the grounding capacitor change to small, the inverter unit no longer comply with the EMC directive.
--	--

Frame size A1Y
VFAS3-6022PC to 6220PC

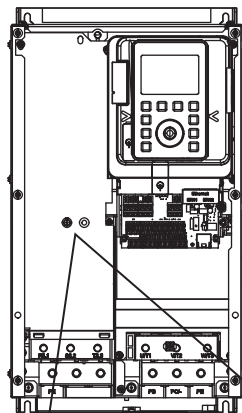

The capacitance of capacitor is switched from Small → Large by mounting the screw on the grounding side.
(Default setting)



The capacitance of capacitor is switched from Large to Small by changing the screw position.

Frame size A2Y
VFAS3-6300PC to 6750PC

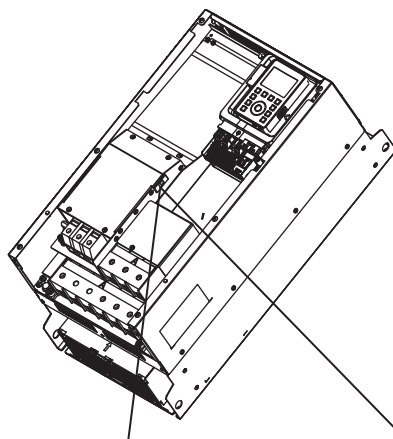

The capacitance of capacitor is switched from Small → Large by moving the switch to right side.
(Default setting)



The capacitance of capacitor is switched from Large → Small by moving the switch to left side.

2. 3. 5 Connect the control wiring and setup

Select sink logic or source logic for digital inputs by slide switch [SW1], then connect for external signals. STO activates ("PrA" into display), if "PLC" is selected and no connection with external reference voltage.

Control terminal block

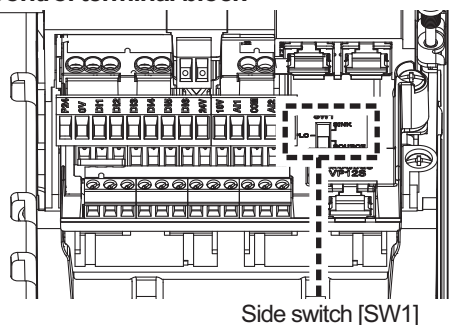

Run command

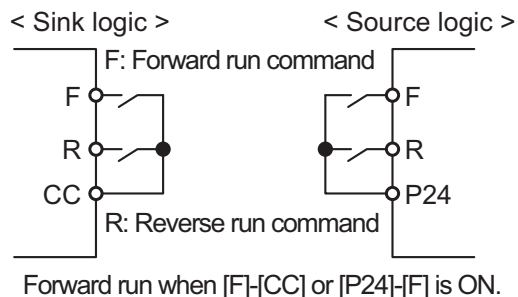

Frequency command

1) Potentiometer

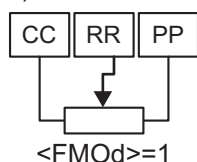

2) Current input (4 to 20mA)

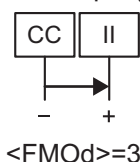

3) Voltage input (0 to 10V) or (-10 to +10V)

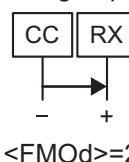

Regarding control terminals and operation, refer to "VF-AS3 instruction manual" (E6582062).

[2. 3. 5 Control terminals]

[3. [Basic operation] Operation panel and screen display]

2. 4 Cautions for application

About cautions for use of the motor and inverter, influence of leakage current on peripheral devices, and measures against it, refer to "VF-AS3 instruction manual" (E6582062), except for the following:

2. 4. 1 Motor

CAUTION



Mandatory
action

- Use the inverter that conforms to specifications of the power supply and the three-phase motor to be operated.
If you use the inappropriate inverter, not only will the three-phase motor not rotate correctly, but it will cause serious accidents such as overheating and burning out.

■ Measures to protect motors against surge voltages

In a system in which this inverter is used to control the operation of a motor, very high surge voltages may be produced depending on the wire length, wire routing and types of wires used.

If such surge voltages are applied repeatedly for a long time, it may cause deterioration of insulation of motor coils.

Here are some examples of measures against surge voltages.

- Decrease <F300: Carrier frequency> of the inverter.
- Use a motor with high insulation strength.

3

Measures to satisfy standards

I

II

1

2

3

4

5

6

7

8

This chapter explains the measures to comply with Low Voltage Directive, EMC Directive, UL/CSA Standards, etc. by introducing examples.

3. 1 How to deal with CE marking

CE mark is put on all products of VF-AS3 to declare that they are in conformity with the requirements of Low Voltage Directive, EMC Directive and Machinery Directive as safety related component.

CE mark must be put on all machines and power drive systems with built-in inverter to conform to EU directives. It is the responsibility of the manufacturers of such final products to put the CE mark on each final product with built-in inverter. We recommend the installation method of inverters and measures described in this instruction manual to conform to these EU directives.

We have tested representative models with them installed under the environment described later in this manual to check for conformity with the EMC Directive. However, we cannot check the inverters under your operating environment. EMC varies depending on the composition of the control panel with a built-in inverter(s), the relationship with other built-in electrical components, the wiring condition, the layout condition, and so on. Therefore, you need to verify yourself whether your machine and system conforms to the EMC Directive.

3. 1. 1 Compliance with EMC Directive

VF-AS3 series comply with EMC directive if the installation and wiring are carried out according to the guideline shown in this section.

The EMC standards are broadly divided into two categories; Emission and Immunity, each of which is further categorized according to the operating environment of each individual machine as shown in the table below. We consider that the tests required for machines and systems as final products are almost the same as those required for inverters.

Category	Subcategory	Product standards	Test standard
Emission	Radiated noise	IEC61800-3	CISPR11 (EN55011)
	Conducted noise		CISPR11 (EN55011)
Immunity	Electrostatic discharge		IEC61000-4-2
	Radio-frequency electromagnetic field		IEC61000-4-3
	Electrical fast transient/burst		IEC61000-4-4
	Surge		IEC61000-4-5
	Conducted radio-frequency common mode		IEC61000-4-6
Voltage dips, short interruptions and voltage variations	IEC61000-4-11		

(1) EMC Directive compliance of this inverter

The built-in EMC filter on the input side of this inverter reduces conducted noise and radiated noise from input cables. The compliance with the EMC Directive is as shown in the table below.

Type-Form	Carrier frequency <F300>	Conducted noise IEC61800-3 category C3 (EN55011 class A Group 2)
		Length of motor connecting cable
	(kHz)	(m)
VFAS3-6022PC	4.0	25
VFAS3-6030PC		
VFAS3-6040PC		
VFAS3-6055PC		
VFAS3-6075PC		
VFAS3-6110PC		
VFAS3-6150PC		
VFAS3-6185PC		
VFAS3-6220PC		
VFAS3-6300PC	2.5	25
VFAS3-6370PC		
VFAS3-6450PC		
VFAS3-6550PC		
VFAS3-6750PC		

(2) Examples of measures to comply with EMC Directive

The following are measures to comply with EMC directive when installing VF-AS3 inverters in your systems.

- Examples of general measures
- When adding an EMC filter for further reduction of noise
- Measures for operation with external signals

The following are general EMC measures explained concretely.

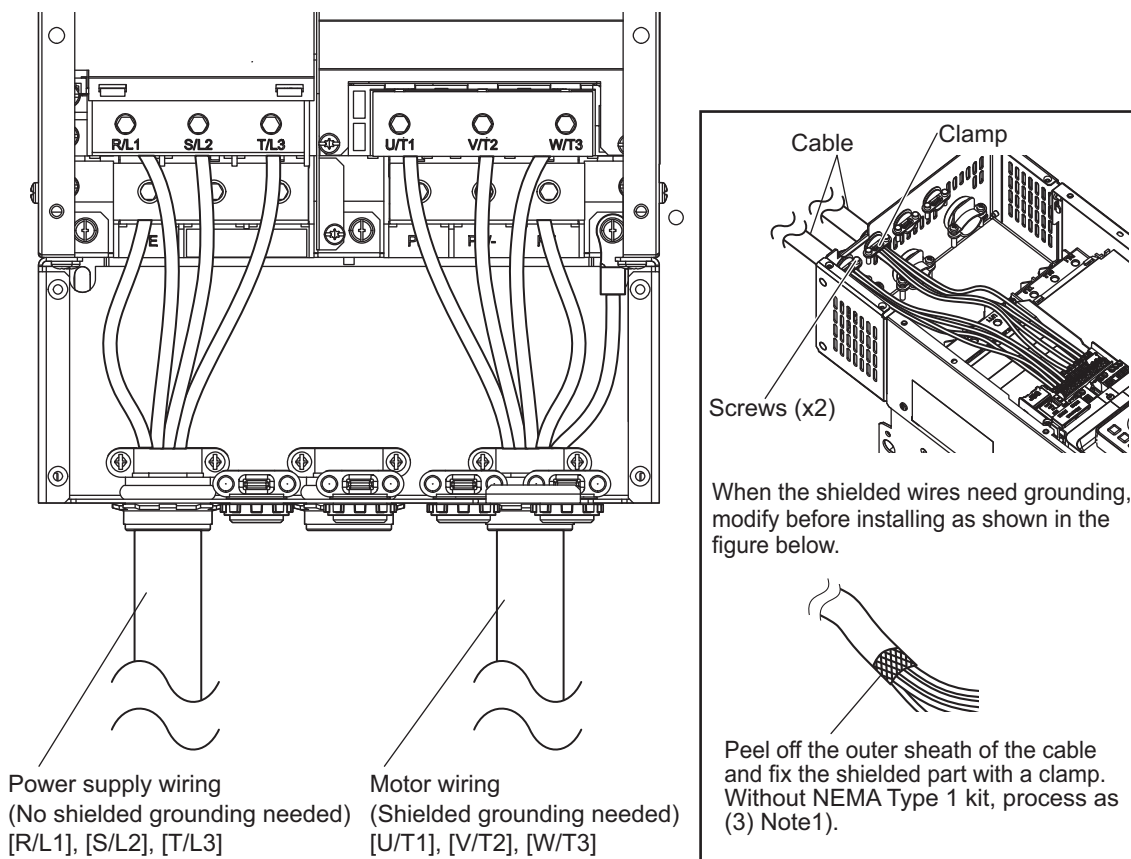

Using shielded power wires and shielded control wires

- Use shielded power wires, such as inverter input/output wires, and shielded control wires.
- Route the wires and wires so as to minimize their lengths.
- Keep a distance between the power cable and the control wire and between the input and output wires of the power cable. Do not route them in parallel or bind them together. Instead, if necessary, cross at right angle.

Installing inverter in steel cabinet (in case of without NEMA Type 1 kit)

- Install the inverter in a sealed steel cabinet.
- Using wires as thick and short as possible, ground the metal plate and the control panel securely with a distance kept between the grounding wire and the power wire.

Routing input and output wires apart

- Route the input and output wires apart as far as possible from each other.

Grounding of shielded wires

- To ground shielded wires through a metal conduit.
- To ground the shielded control wires by fixing the metal saddle of the body.
- Inserting a ferrite core in a shielded wire is even more effective in limiting the radiated noise.

Inserting zero-phase reactor and ferrite cores

- Insert a zero-phase reactor in the inverter output line.
- Insert ferrite cores in the grounding wires of the metal plate.

NEMA Type 1

- NEMA Type 1 kit (conduit box and top cover) is option.
- NEMA Type 1 kit is not required to comply with the EMC Directive.

3

(3) Measures for operation with external signals

To operate with external signals, take measures as shown in the figure below (e.g.: using a potentiometer and Fwd/Rev terminals).

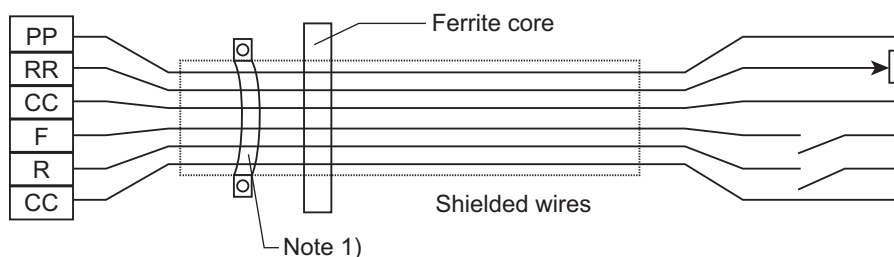

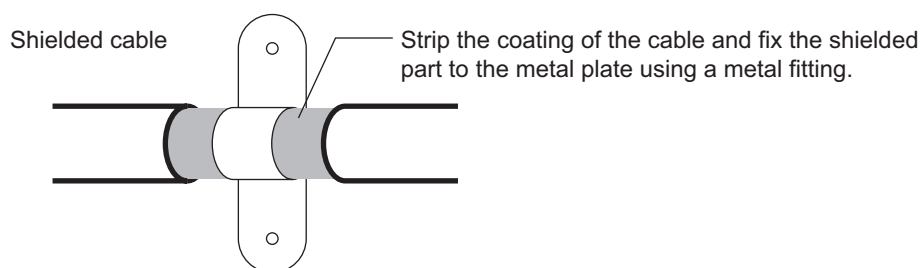

Note 1)

Without NEMA Type 1 kit, process as shown below.



3. 1. 2 Compliance with Low Voltage Directive

WARNING

 Mandatory action	<ul style="list-style-type: none"> • Install proper short-circuit protective device between the power supply and the inverter (primary side). If proper short-circuit protective device is not installed, short circuit current cannot be shut down by inverter alone and it will result in electric shock or fire. Integral solid state short circuit protection in the inverter does not provide branch circuit protection. Branch circuit protection must be provided in accordance with any local codes. • Take into account the minimum required prospective short-circuit current of short-circuit protective device. If short circuit protective device does not work properly due to lower level short-circuit current, it will result in electric shock or fire. • Install the inverter on the wall or into enclosure based on this manual, and install short-circuit protective device or power distribution devices based on the manufacturer manual. When they are installed with improper coordination, this will result in electric shock or fire.
 Be grounded	<ul style="list-style-type: none"> • The grounding wire must be connected securely. If the grounding wire is not securely connected, when the inverter has failure or earth leakage, this will result in electric shock or fire. • The product has a leakage current greater than 3.5 mA. A grounding wire (protective ground conductor) size must be at least 10mm² or two grounding wires with the size as same as original one must be used. Use of improper grounding wire will result in electric shock or fire. The grounding of drive system must be provided in accordance with the national electrical code and any additional local codes.
 Electric shock	<ul style="list-style-type: none"> • Capacitive voltage above 50V may remain for 15 minutes after power is disconnected. Wiring or servicing must be performed under the capacitive voltage below 50V. Otherwise, it will result in electric shock.

CAUTION

 Mandatory action	<ul style="list-style-type: none"> • This product can cause a DC current in the PE conductor. Where a residual current operated protective device (RCD) is used for protection against electric shock, only an RCD of Type B is allowed on the supply side of this product. All upstream RCD, up to the supply transformer, shall be of Type B. If proper device above is not used, it can result in electric shock.
---	---

Inverters are CE-marked in accordance with the requirement of Low Voltage Directive, and can therefore be installed in power drive system and exported without problem to EU countries.

- Applicable standard: EN61800-5-1 (IEC61800-5-1)
- Pollution degree: 2
- Overvoltage category: III*

* Drive operating altitude is less or equal to 2,000m with TT/TN/IT system.

The drive can be operated 2,000m with an isolated transformer to pass an overvoltage category II and limited to 4,800m with TT/TN/IT system.

- The electronic power output short-circuit protection circuitry meets the requirements of IEC60364-4-41:2005/AMD1 - Clause 411.

When incorporating the inverter into a power drive system, take the following measures to comply with Low Voltage Directive.

(1) Installation and upstream protection devices

- Install the inverter on a wall or into the enclosure with proper short circuit protective device (SCPD) in accordance with the table of prospective short-circuit current (Isc) rating shown in following pages.

(2) Grounding

- Connect a dedicated wire to the grounding terminal on the inverter.
- Ground each inverter directly when grounding multiple inverters.
- Refer to the table in [4. 1] to select wire size.

A grounding wire size must be at least 10mm². Also two grounding wires can be used with the same size as that of [4. 1]. The grounding of drive system must be provided in accordance with the national electrical code and any additional local codes.

(3) Overload protection

- For overload protection of inverter, refer to [5. 2. 5], [5. 3. 2] of VF-AS3 instruction manual (E6582062).

(4) Motor overload protection and overtemperature protection

- For electronic motor thermal protection, refer to [5. 2. 5] of VF-AS3 instruction manual (E6582062).
- For motor integrated PTC thermal protection, refer to [6. 30. 19] of VF-AS3 instruction manual (E6582062).



Important

- Motor thermal protection should be used with <F607: Motor overload time> = 300 (default setting) or less.

■ Prospective short-circuit current rating (Isc) table - with enclosure

The rating of the short circuit protection devices (SCPD) in the table below are maximum values with Enclosure in Normal Duty. Smaller sizes can be used (ex. in Heavy Duty). Use the wire with the size described in [4. 1]. Short-circuit protection of drive system must be provided in accordance with the national electrical code and any additional local codes.

Type-form *1	Maximum Input Voltage (V)	Applicable motor (kW)	Maximum Isc (kA)	SCPD rating		Minimum line reactor (mH)	Minimum enclosure volume (L)
				Fuse gG *2 (A)	Circuit breaker *3, *4		
VFAS3-6022PC	690	3	70	8	GV2L10	-	142
VFAS3-6030PC		4	70	10	GV2L14	-	142
VFAS3-6040PC		5.5	70	16	GV2L14	-	142
VFAS3-6055PC		7.5	70	20	GV2L16	-	142
VFAS3-6075PC		11	70	25	GV2L20	-	142
VFAS3-6110PC		15	70	32	GV2L22	-	142
VFAS3-6150PC		18.5	70	40	GV3L25	-	142
VFAS3-6185PC		22	70	50	GV3L32	-	142
VFAS3-6220PC		30	70	63	GV3L40	-	142
VFAS3-6300PC		37	70	80	GV3L50	-	283
VFAS3-6370PC		45	70	100	GV3L65	-	283
VFAS3-6450PC		55	70	100	C10□3MA100	-	283
VFAS3-6550PC		75	70	125	C10□3MA100	-	283
VFAS3-6750PC		90	70	160	C16□3MA150	-	283

*1 Type-form may be followed by any characters.

*2 Mersen is recommended supplier.

*3 Tesys GV series or ComPact series from Schneider Electric are recommended. Choose □ in the part number according to the breaking capacity.

*4 PowerPact series from Schneider Electric are also available, see [3. 2. 4], choose the part number according to the short-circuit current rating.

■ Prospective short-circuit current rating (Isc) table - on a wall

The rating of the short circuit protection devices (SCPD) in the table below are maximum values without enclosure in Normal Duty. Smaller sizes can be used (ex. in Heavy Duty). Use the wire with the size described in [4. 1]. Short-circuit protection of drive system must be provided in accordance with the national electrical code and any additional local codes.

Type-form ^{*1}	Maximum Input Voltage	Applicable motor	Maximum Isc	SCPD rating (semiconductor fuse: IEC60269-4)					
				gR ^{*3} 690V		gS ^{*3} 690V		aR ^{*3*4} 690V	
				Rating	Min.	Rating	Min.	Rating	Min.
				(A)	Size	(A)	Size	(A)	Size
VFAS3-6022PC ^{*2}	690	3	70	8	10x38	-	-	-	-
VFAS3-6030PC ^{*2}		4	70	10	10x38	-	-	-	-
VFAS3-6040PC ^{*2}		5.5	70	16	10x38	16	000	16	000
VFAS3-6055PC ^{*2}		7.5	70	20	10x38	20	000	20	000
VFAS3-6075PC ^{*2}		11	70	25	10x38	25	000	25	000
VFAS3-6110PC ^{*2}		15	70	32	10x38	32	000	32	000
VFAS3-6150PC ^{*2}		18.5	70	40	14x51	40	000	40	000
VFAS3-6185PC ^{*2}		22	70	50	14x51	50	000	50	000
VFAS3-6220PC ^{*2}		30	70	63	22x58	63	000	63	000
VFAS3-6300PC ^{*2}		37	70	-	-	80	000	80	000
VFAS3-6370PC ^{*2}		45	70	-	-	100	000	100	000
VFAS3-6450PC ^{*2}		55	70	-	-	100	000	100	000
VFAS3-6550PC ^{*2}		75	70	-	-	125	00	125	000
VFAS3-6750PC ^{*2}		90	70	-	-	160	00	160	000

*1 Type-form may be followed by any characters.

*2 Install proper option kit (NEM031Z or NEM302Z), otherwise install the product into an enclosure.

*3 Mersen is recommended supplier.

*4 Install a proper overload protection in case of using aR type fuse.

3. 1. 3 Compliance with safety standards

Refer to “VF-AS3 Safety function manual” (E6582067).

3. 1. 4 Compliance with ATEX directive

This inverter has not applied for ATEX directive.

3. 1. 5 Declaration of Conformity

Declaration of Conformity is available via the internet at
"<https://www.toshiba-tips.co.jp/en/products/inverter/>"

3. 1. 6 Compliance of Ecodesign

VF-AS3 series inverter (variable speed drive) conform to Ecodesign requirements* by Commission Regulation (EU). For the detailed technical data, refer to its nameplate and the technical data via the internet at
"<https://www.toshiba-tips.co.jp/en/products/inverter/>"

* Ecodesign requirements framework was established by Directive 2009/125/EC.



3.2 Compliance with UL/CSA Standards

VF-AS3 that comply with UL/CSA Standard have the mark to prove the compliance on the nameplate. This section shows the detail information for VF-AS3 UL/CSA compliance.

3.2.1 General

WARNING / AVERTISSEMENT



Electric shock

- Capacitive voltage above 50V may remain for 15 minutes after power is disconnected. Wiring or servicing must be performed under the capacitive voltage below 50V. Otherwise, it will result in electric shock.
- Des tensions subsistent aux bornes des condensateurs pendant 15 minutes après l'ouverture de circuit d'entree. Le câblage ou l'entretien doit être effectué sous une tension capacitive inférieure à 50 V. Sinon, cela entraînerait un choc électrique.

The following steps must be performed before wiring and servicing.

- (1) Turn off all input power.
 - (2) Wait at least fifteen minutes and check to make sure that the charge lamp is no longer lit.
 - (3) Use a tester that can measure DC voltage (1400VDC or more), and check to make sure that the voltage to the DC power circuits (across PA/+ and PC/-) is 45V or less.
- If these steps are not properly performed, the wiring will cause electric shock.



Important

- Keep original "DANGER" or "WARNING" labels visibility on front cover for UL/CSA compliance.
- The input power supply for UL/CSA compliance is 500 to 600V - 50/60Hz.

3. 2. 2 Compliance with Installation

A UL certificate was granted on the assumption that the VF-AS3 inverter with NEMA Type 1 kit would be installed on a wall or the VF-AS3 inverter would be installed in an enclosure. Therefore, if necessary, take measures to maintain the inverter ambient temperature (temperature in the enclosure) within the specified temperature range.

Standard installation

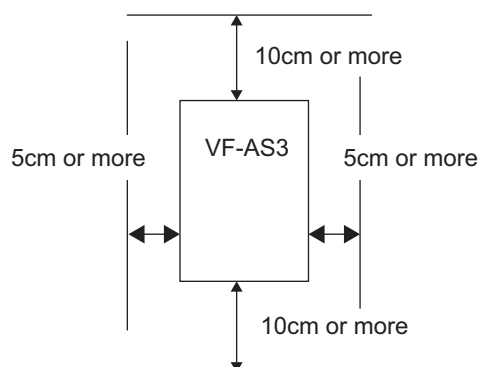

3

Environments

Input voltage range	500 to 600Vac (TN/TT/IT system)
Overvoltage category	OVCIII The optional relays ([FLA], [FLB], [FLC], [R1A], [R1C], [R2A] and [R2C] terminals) need to be supplied by an isolating device tapped from the mains. The Relay circuit is considered OVC II.
Ambient temperature	-10 to +50°C (Maximum ambient temperature)
Storage temperature	-25 to +70°C (Temperature applicable for a short term.)
Relative humidity	5 to 95% (free from condensation and vapor).
Pollution degree	2
Elevation	2000m or less Current reduction is required for 1000m and above. Above 1000m, a 1% current reduction is required every 100m. (90% current reduction required at 2000m)

Refer to [2. 1] for installation or [Chapter 6] for the specification not listed in the table above.

3. 2. 3 Compliance with Connection

WARNING / AVERTISSEMENT

The opening of the branch circuit protective device may be an indication that a fault current has been interrupted. To reduce the risk of fire or electrical shock, current-carrying parts and other components of the controller should be examined and replaced if damaged.

If burnout of the current element of an overload relay occurs, the complete overload relay must be replaced.

(LE DÉCLENCHEMENT DU DISPOSITIF DE PROTECTION DU CIRCUIT DE DÉRIVATION PEUT ÊTRE DÙ À UNE COUPURE QUI RÉSUITE D'UN COURANT DE DÉFAUT. POUR LIMITER LE RISQUE D'INCENDIE OU DE CHOC ÉLECTRIQUE, EXAMINER LES PIÈCES PORTEUSES DE COURANT ET LES AUTRES ÉLÉMENTS DU CONTRÔLEUR ET LES REMPLACER S'ILS SONT ENDOMMAGÉS. EN CAS DE GRILLAGE DE L'ÉLÉMENT TRAVERSÉ PAR LE COURANT DANS UN RELAIS DE SURCHARGE, LE RELAIS TOUT ENTIER DOIT ÊTRE REMPLACÉ)

Use the UL conformed cables (Rating 75°C or more, Use the copper conductors only.) to the power circuit terminals ([R/L1], [S/L2], [T/L3], [U/T1], [V/T2], [W/T3]), UL-certified electric wire for [FLA], [FLB], [FLC], [R1A], [R1C], [R2A] and [R2C] terminals.

For instruction in the United States, Integral solid state short circuit protection does not provide branch circuit protection. Branch circuit protection must be provided in accordance with the National Electrical Code and any additional local codes.

For instruction in the Canada, Integral solid state short circuit protection does not provide branch circuit protection. Branch circuit protection must be provided in accordance with the Canadian Electrical Code Part I.

(La protection intégrée contre les courts-circuits n'assure pas la protection de la dérivation. La protection de la dérivation doit être exécutée conformément au code Canadien de l'électricité, première partie.)

=> For recommended tightening torque, refer to the [2. 3. 3]

=> For recommended electric wire sizes, refer to the [3. 2. 4]

=> Use the electric wire of Class1 for the control circuits.

For details of power wiring, terminals and function, refer to the [2. 3].

For details of control wiring, terminals and the functions, refer to [2. 3. 5] of "VF-AS3 instruction manual" (E6582062).

3. 2. 4 Cautions for peripheral devices

For this inverter, a UL test has been performed under the condition of the power supply short-circuit currents shown as follows. These allow proper coordination of short circuit protection.

Suitable for use on a circuit capable of delivering not more than ___X___ rms symmetrical kilo Amperes, ___Y___ Volts maximum, when protected by ___Z1___ with a maximum rating of ___Z2___ . Where X, Y, Z1 and Z2 are indicated in following table.

(Convient aux circuits non susceptibles de délivrer plus de ___X___ ampères symétriques efficaces, maximum ___Y___ V, avec protection par ___Z1___ de calibre nominal de ___Z2___ .

Où X, Y, Z1 et Z2 sont indiqués dans le tableau suivant.)

■ Short-Circuit Current Rating (SCCR) and Wire size

Inverter model	Maximum voltage (V)	Applicable motor		SCCR (kA)	Branch circuit protection		Power wire sizes* ³ (AWG)		Grounding wire sizes* ^{3*4} (AWG)	Minimum Enclosure Volume (cu. in.)* ⁵
		(kW)	(HP)		with Fuses* ¹ * ²		Input	Output		
					Class	Rating (A)				
Marking	Y	-	-	X	Z1	Z2	-	-	-	-
VFAS3-6022PC	600	2.2	3	100	Class J	10	12	12	12	8640
VFAS3-6030PC		3	—	100	Class J	15	12	12	12	8640
VFAS3-6040PC		4	5	100	Class J	15	12	12	12	8640
VFAS3-6055PC		5.5	7.5	100	Class J	15	12	12	12	8640
VFAS3-6075PC		7.5	10	100	Class J	20	12	12	12	8640
VFAS3-6110PC		11	15	100	Class J	25	10	10	10	8640
VFAS3-6150PC		15	20	100	Class J	30	10	10	10	8640
VFAS3-6185PC		18.5	25	100	Class J	35	8	8	8	8640
VFAS3-6220PC		22	30	100	Class J	40	8	8	8	8640
VFAS3-6300PC		30	40	100	Class J	60	4	2	2	17280
VFAS3-6370PC		37	50	100	Class J	70	4	2	2	17280
VFAS3-6450PC		45	60	100	Class J	80	4	2	2	17280
VFAS3-6550PC		55	75	100	Class J	110	2	2	2	17280
VFAS3-6750PC		75	100	100	Class J	150	1/0	1/0	2	17280

*1 The rating of fuses in the table are maximum values. Smaller rating fuses can be used for HD ratings. Branch circuit protection must be provided in accordance with the National Electrical Code and any additional local codes.

*2 Bussmann or Mersen are recommended supplier.

*3 The wire size is the one when 75°C is continuously allowed (ambient temperature of 40°C or less).

*4 Use the UL recognized ring terminal for grounding wire on sheet metal.

VFAS3-6022PC to 6150PC: R5.5-5

VFAS3-6185PC to 6220PC: R8-5

VFAS3-6300PC to 6750PC: R38-8

*5 Install the unit in Type 1 cabinet with the minimum enclosure volume (cubic inch) shown in the table.

In case of using circuit breaker as branch circuit protection, the conditions of the power supply shortcircuit currents are shown in the following table.

Inverter model	Maximum voltage (V)	Applicable motor		SCCR (kA)	Branch circuit protection		Minimum Enclosure Volume (cu. in.) ^{*3}	Minimum line reactor
		(kW)	(HP)		with Circuit Breakers ^{*1 *2}			
					Model	Rating (A)		
Marking	Y	-	-	X	Z1	Z2	-	-
VFAS3-6022PC	600	2.2	3	100	HRL36015	15	8640	-
VFAS3-6030PC		3	-	100	HRL36020	20	8640	-
VFAS3-6040PC		4	5	100	HRL36020	20	8640	-
VFAS3-6055PC		5.5	7.5	100	HRL36025	25	8640	-
VFAS3-6075PC		7.5	10	100	HRL36040	40	8640	-
VFAS3-6110PC		11	15	100	HRL36050	50	8640	-
VFAS3-6150PC		15	20	100	HRL36060	60	8640	-
VFAS3-6185PC		18.5	25	100	HRL36080	80	8640	-
VFAS3-6220PC		22	30	100	HRL36100	100	8640	-
VFAS3-6300PC		30	40	100	HRL36125	125	17280	-
VFAS3-6370PC		37	50	100	HRL36150	150	17280	-
VFAS3-6450PC		45	60	100	HRL36150	150	17280	-
VFAS3-6550PC		55	75	100	JRL36200	200	17280	-
VFAS3-6750PC		75	100	100	JRL36250	250	17280	-

*1 The rating of circuit breakers in the table are maximum values. Smaller rating one can be used for HD ratings. Branch circuit protection must be provided in accordance with the National Electrical Code and any additional local codes.

*2 Use a circuit breaker of Schneider Electric.

*3 Install the unit in Type 1 cabinet with the minimum enclosure volume (cubic inch) shown in the table.

■ Short-Circuit Current Rating (SCCR) and Wire size with NEMA Type 1 kit

Inverter model With IP20/NEMA Type 1 conformity kit	Maximum voltage (V)	Applicable motor		SCCR (kA)	Branch circuit protection		Power wire sizes ^{*3}	Grounding wire sizes ^{*3 *4}
		(kW)	(HP)		with Fuses ^{*1 *2}			
					Class	Rating (A)		
Marking	Y	-	-	X	Z1	Z2	-	-
VFAS3-6022PC	600	2.2	3	100	Class J	10	AWG 12	AWG 12
VFAS3-6030PC		3	-	100	Class J	15	AWG 12	AWG 12
VFAS3-6040PC		4	5	100	Class J	15	AWG 12	AWG 12
VFAS3-6055PC		5.5	7.5	100	Class J	15	AWG 12	AWG 12
VFAS3-6075PC		7.5	10	100	Class J	20	AWG 12	AWG 12
VFAS3-6110PC		11	15	100	Class J	25	AWG 10	AWG 10
VFAS3-6150PC		15	20	100	Class J	30	AWG 10	AWG 10
VFAS3-6185PC		18.5	25	100	Class J	35	AWG 8	AWG 8
VFAS3-6220PC		22	30	100	Class J	40	AWG 8	AWG 8
VFAS3-6300PC		30	40	100	Class J	60	AWG 4	AWG 2
VFAS3-6370PC		37	50	100	Class J	70	AWG 4	AWG 2
VFAS3-6450PC		45	60	100	Class J	80	AWG 4	AWG 2
VFAS3-6550PC		55	75	100	Class J	110	AWG 2	AWG 2
VFAS3-6750PC		75	100	100	Class J	150	AWG 1/0	AWG 2

*1 The rating of fuses in the table are maximum values. Smaller rating fuses can be used for HD ratings. Branch circuit protection must be provided in accordance with the National Electrical Code and any additional local codes.

*2 Bussmann or Mersen are recommended supplier.

*3 The wire size is the one when 75°C is continuously allowed (ambient temperature of 40°C or less).

*4 Use the UL recognized ring terminal for grounding wire on sheet metal.

VFAS3-6022PC to 6150PC: R5.5-5

VFAS3-6185PC to 6220PC: R8-5

VFAS3-6300PC to 6750PC: R38-8

3. 2. 5 Overload protection

The overload protection levels are below,
 HD rating: 150%-1minute
 ND rating: 120%-1minute

Overload protection rated in percent of the rated current described on name plate. Refer to [5. 2. 5] of VF-AS3 instruction manual (E6582062) for details.

3. 2. 6 Motor thermal protection

3

NOTICE / AVIS



Mandatory
action

- Set motor thermal protection according to motor rating.
If motor thermal protection is not set, it can result in motor damage.
- Réglez la protection thermique du moteur en fonction de sa puissance nominale.
Si la protection thermique du moteur n'est pas réglée, cela peut entraîner des dommages au moteur.

To use the electronic thermal function of this inverter for motor thermal protection, set parameters according to the motor specifications applied. For details, refer to [5. 2. 5] of "VF-AS3 instruction manual" (E6582062).

When operating multiple motors with one inverter, install overload relay for each motor.



Important

- Motor thermal protection should be used with <F607: Motor overload time> = 300 (default setting) or less.

3. 2. 7 Motor integrated PTC thermal protection

For details, refer to [6. 30. 19] of "VF-AS3 instruction manual" (E6582062).

3. 2. 8 Other

Contact your Toshiba distributor or Toshiba sales representative (see the back cover of this manual), if you need the hard copy (paper) of "VF-AS3 instruction manual" (E6582062).

4

Selection and installation of peripheral devices

I

II

1

2

3

4

5



6

7

8

In this chapter, the selection and installation methods of peripheral devices for this inverter are described.

WARNING

 Mandatory action	<ul style="list-style-type: none">In using a power distribution device and external options for the inverter, they must be installed in a cabinet. When they are not installed in the cabinet, this will result in electric shock.
 Be grounded	<ul style="list-style-type: none">The grounding wire must be connected securely. If the grounding wire is not securely connected, when the inverter has failure or earth leakage, this will result in electric shock or fire.

NOTICE

 Mandatory action	<ul style="list-style-type: none">All options to be used must be those specified by Toshiba. The use of options other than those specified by Toshiba will result in an accident.
---	---

4.1 Selection of wire size

According to the voltage class and capacity of the inverter, perform wiring using appropriate wires as shown in the table below. When connecting peripheral devices to the inverter also, perform wiring according to the wire size for a wire location shown in the table below.

- The recommended cable size is that of the cable (e.g. 1500V class copper cable) with continuous maximum permissible temperature of 75°C.
Ambient temperature is 40°C or less and the wiring distance is 30m or less.
- For the wire of the control circuit, use a shielded wire with 0.75 mm² or more.

■ Wire size for 500V, 690V class HD rating

Frame size	Reference	Wire size (mm ²)				
		Input	Output	DC	Brake	Ground
A1Y	VFAS3-6022PC	4	4	4	4	4
	VFAS3-6030PC	4	4	4	4	4
	VFAS3-6040PC	4	4	4	4	4
	VFAS3-6055PC	4	4	4	4	4
	VFAS3-6075PC	4	4	4	4	4
	VFAS3-6110PC	4	4	4	4	4
	VFAS3-6150PC	4	4	4	4	4
	VFAS3-6185PC	4	4	4	4	4
	VFAS3-6220PC	6	6	6	4	6
A2Y	VFAS3-6300PC	25	35	35	35	35
	VFAS3-6370PC	25	35	35	35	35
	VFAS3-6450PC	25	35	35	35	35
	VFAS3-6550PC	25	35	35	35	35
	VFAS3-6750PC	35	35	35	35	35

*1 Input: [R/L1], [S/L2], [T/L3] terminals
 Output: [U/T1], [V/T2], [W/T3] terminals
 DC: [PA/+], [PB], [PC/-] terminals
 Brake: [PA/+], [PB] terminals
 Ground: [PE] terminal and inverter case

*2 Tightening torque and cable range

A1Y	Tightening torque	4 mm ² : 3 N·m
		6 mm ² : 5.4 N·m
		10 mm ² : 12 N·m
A1Y	Cable range	1.3mm ² - 53mm ²
A2Y	Tightening torque	Input : 8 N·m
		Output/DC/Brake/Ground : 41 N·m
	Cable range	Input 25mm ² - 50mm ²
		Other 33.6mm ² - 152mm ²

■ Wire size for 500V, 690V class ND rating

Frame size	Reference	Wire size (mm ²)				
		Input	Output	DC	Brake	Ground
A1Y	VFAS3-6022PC	4	4	4	4	4
	VFAS3-6030PC	4	4	4	4	4
	VFAS3-6040PC	4	4	4	4	4
	VFAS3-6055PC	4	4	4	4	4
	VFAS3-6075PC	4	4	4	4	4
	VFAS3-6110PC	4	4	4	4	4
	VFAS3-6150PC	4	4	4	4	4
	VFAS3-6185PC	6	6	6	4	6
	VFAS3-6220PC	10	10	10	10	10
A2Y	VFAS3-6300PC	25	35	35	35	35
	VFAS3-6370PC	25	35	35	35	35
	VFAS3-6450PC	25	35	35	35	35
	VFAS3-6550PC	35	35	35	35	35
	VFAS3-6750PC	50	50	50	50	35

*1 Input: [R/L1], [S/L2], [T/L3] terminals
 Output: [U/T1], [V/T2], [W/T3] terminals
 DC: [PA/+], [PB], [PC/-] terminals
 Brake: [PA/+], [PB] terminals
 Ground: [PE] terminal and inverter case

*2 Tightening torque and cable range

A1Y	Tightening torque	4 mm ² : 3 N·m
		6 mm ² : 5.4 N·m
		10 mm ² : 12 N·m
A1Y	Cable range	1.3mm ² - 53mm ²
A2Y	Tightening torque	Input : 8 N·m
		Output/DC/Brake/Ground : 41 N·m
	Cable range	Input: 25mm ² - 50mm ²
Other: 33.6mm ² - 152mm ²		

■ Wire size for 600V(575V) class HD rating

Frame size	Reference	Wire size (AWG)				
		Input	Output	DC	Brake	Ground
A1Y	VFAS3-6022PC	12	12	12	12	12
	VFAS3-6030PC	12	12	12	12	12
	VFAS3-6055PC	12	12	12	12	12
	VFAS3-6075PC	12	12	12	12	12
	VFAS3-6110PC	12	12	12	12	12
	VFAS3-6150PC	10	10	10	12	10
	VFAS3-6185PC	10	10	10	12	10
	VFAS3-6220PC	8	8	8	10	8
A2Y	VFAS3-6300PC	4	2	2	2	2
	VFAS3-6370PC	4	2	2	2	2
	VFAS3-6450PC	4	2	2	2	2
	VFAS3-6550PC	3	2	2	2	2
	VFAS3-6750PC	2	2	2	2	2

- *1 Input: [R/L1], [S/L2], [T/L3] terminals
 Output: [U/T1], [V/T2], [W/T3] terminals
 DC: [PA/+], [PB], [PC/-] terminals
 Brake: [PA/+], [PB] terminals
 Ground: [PE] terminal and inverter case

- *2 Tightening torque and cable range

A1Y	Tightening torque	12 AWG : 26.5 lb·in
		10 AWG : 47.7 lb·in
		8 AWG : 106.2 lb·in
	Cable range	16 AWG - 1/0 AWG
A2Y	Tightening torque	Input : 70.8 lb·in
		Output/DC/Brake/Ground : 363 lb·in
	Cable range	Input: 4 AWG - 1/0 AWG
		Other: 2 AWG - 300 kcmil

■ Wire size for 600V(575V) class ND rating

Frame size	Reference	Wire size (AWG)				
		Input	Output	DC	Brake	Ground
A1Y	VFAS3-6022PC	12	12	12	12	12
	VFAS3-6040PC	12	12	12	12	12
	VFAS3-6055PC	12	12	12	12	12
	VFAS3-6075PC	12	12	12	12	12
	VFAS3-6110PC	10	10	10	12	10
	VFAS3-6150PC	10	10	10	10	10
	VFAS3-6185PC	8	8	8	10	8
	VFAS3-6220PC	8	8	8	8	8
A2Y	VFAS3-6300PC	4	2	2	2	2
	VFAS3-6370PC	4	2	2	2	2
	VFAS3-6450PC	4	2	2	2	2
	VFAS3-6550PC	2	2	2	2	2
	VFAS3-6750PC	1/0	1/0	1/0	2	2

- *1 Input: [R/L1], [S/L2], [T/L3] terminals
 Output: [U/T1], [V/T2], [W/T3] terminals
 DC: [PA/+], [PB], [PC/-] terminals
 Brake: [PA/+], [PB] terminals
 Ground: [PE] terminal and inverter case

- *2 Tightening torque and cable range

A1Y	Tightening torque	12 AWG : 26.5 lb·in
		10 AWG : 47.7 lb·in
		8 AWG : 106.2 lb·in
	Cable range	16 AWG - 1/0 AWG
A2Y	Tightening torque	Input : 70.8 lb·in
		Output/DC/Brake/Ground : 363 lb·in
	Cable range	Input: 4 AWG - 1/0 AWG
		Other: 2 AWG - 300 kcmil

Memo

- The wire size of this chapter comply with IEC60364-5-52 (Grounding wire: IEC60364-5-54).
- Refer to [3. 2. 4] for UL standard compliance, [3. 1. 2] for Low voltage directive.
- The wire size must be selected in accordance with the national electrical code and any additional local codes.

4.2 Selection of a wiring device

According to the table [4. 2. 1], select an appropriate wiring device depending on the voltage class and capacity of the inverter.

4.2.1 Selection table of a wiring device

Select a wiring device depending on the inverter type and input current in the following tables.

■ Wiring devices for 500V class HD rating

Type-Form	Applicable motor capacity	Input current (A)	Rated current (A)	
			Molded-case circuit breaker (MCCB) Earth leakage circuit breaker (ELCB)	Magnetic contactor (MC) AC-1
VFAS3-6022PC	1.5 kW	3.4	7.5	5
VFAS3-6030PC	2.2 kW	4.7	7.5	7.5
VFAS3-6040PC	3 kW	6.2	12.5	7.5
VFAS3-6055PC	4 kW	7.9	12.5	10
VFAS3-6075PC	5.5 kW	10.4	15	15
VFAS3-6110PC	7.5 kW	13.6	25	15
VFAS3-6150PC	11 kW	18.4	30	25
VFAS3-6185PC	15 kW	23.1	35	30
VFAS3-6220PC	18.5 kW	27.6	40	40
VFAS3-6300PC	22 kW	37.7	65	60
VFAS3-6370PC	30 kW	47.2	80	60
VFAS3-6450PC	37 kW	55.6	80	80
VFAS3-6550PC	45 kW	71.0	100	80
VFAS3-6750PC	55 kW	82.7	125	100

- This is the selection when using a Toshiba standard 4-pole motor with input of 500V-50Hz.
- Install a surge absorber on the exciting coil of a magnetic contactor (MC) and relays.
- When using an auxiliary contacts 2a type magnetic contactor (MC), use the 2a contacts in parallel to increase the liability of the contacts.
- The magnitude of the short-circuit current varies depending on the power supply capacity and wiring system conditions, so select the MCCB with the rated breaking current that matches the capacity. This table is selected assuming a general power supply capacity.
- For the influence of the leakage current, refer to [2. 4. 3] of "VF-AS3 instruction manual" (E6582062).

■ Wiring devices for 600V(575V) class HD rating

Type-Form	Applicable motor capacity	Input current (A)	Rated current (A)	
			Molded-case circuit breaker (MCCB) Earth leakage circuit breaker (ELCB)	Magnetic contactor (MC) AC-1
VFAS3-6022PC	2 HP	3.0	7.5	5
VFAS3-6030PC	3 HP	4.1	7.5	7.5
VFAS3-6055PC	5 HP	6.9	12.5	10
VFAS3-6075PC	7.5 HP	9.0	15	15
VFAS3-6110PC	10 HP	11.8	25	20
VFAS3-6150PC	15 HP	16.1	35	25
VFAS3-6185PC	20 HP	20.1	35	30
VFAS3-6220PC	25 HP	23.9	40	40
VFAS3-6300PC	30 HP	33.0	65	50
VFAS3-6370PC	40 HP	41.2	80	60
VFAS3-6450PC	50 HP	48.5	80	80
VFAS3-6550PC	60 HP	61.7	100	80
VFAS3-6750PC	75 HP	71.9	125	100

- This is the selection when using a Toshiba standard 4-pole motor with input of 575V-60Hz.
- Install a surge absorber on the exciting coil of a magnetic contactor (MC) and relays.
- When using an auxiliary contacts 2a type magnetic contactor (MC), use the 2a contacts in parallel to increase the liability of the contacts.
- The magnitude of the short-circuit current varies depending on the power supply capacity and wiring system conditions, so select the MCCB with the rated breaking current that matches the capacity. This table is selected assuming a general power supply capacity.
- For the influence of the leakage current, refer to [2. 4. 3] of "VF-AS3 instruction manual" (E6582062).

■ Wiring devices for 690V class HD rating

Type-Form	Applicable motor capacity	Input current (A)	Rated current (A)	
			Molded-case circuit breaker (MCCB) Earth leakage circuit breaker (ELCB)	Magnetic contactor (MC) AC-1
VFAS3-6022PC	2.2 kW	3.6	7.5	5
VFAS3-6030PC	3 kW	4.8	7.5	7.5
VFAS3-6040PC	4 kW	6.1	12.5	7.5
VFAS3-6055PC	5.5 kW	8.0	12.5	10
VFAS3-6075PC	7.5 kW	10.5	15	15
VFAS3-6110PC	11 kW	14.7	25	20
VFAS3-6150PC	15 kW	19.2	30	25
VFAS3-6185PC	18.5 kW	23.0	35	30
VFAS3-6220PC	22 kW	26.0	40	30
VFAS3-6300PC	30 kW	38.5	65	60
VFAS3-6370PC	37 kW	46.2	65	60
VFAS3-6450PC	45 kW	54.4	80	60
VFAS3-6550PC	55 kW	68.5	100	80
VFAS3-6750PC	75 kW	87.8	125	100

- This is the selection when using a Toshiba standard 4-pole motor with input of 690V-50Hz.
- Install a surge absorber on the exciting coil of a magnetic contactor (MC) and relays.
- When using an auxiliary contacts 2a type magnetic contactor (MC), use the 2a contacts in parallel to increase the liability of the contacts.
- The magnitude of the short-circuit current varies depending on the power supply capacity and wiring system conditions, so select the MCCB with the rated breaking current that matches the capacity. This table is selected assuming a general power supply capacity.
- For the influence of the leakage current, refer to [2. 4. 3] of "VF-AS3 instruction manual" (E6582062).

■ Wiring devices for 500V class ND rating

Type-Form	Applicable motor capacity	Input current (A)	Rated current (A)	
			Molded-case circuit breaker (MCCB) Earth leakage circuit breaker (ELCB)	Magnetic contactor (MC) AC-1
VFAS3-6022PC	2.2 kW	4.7	7.5	7.5
VFAS3-6030PC	3 kW	6.2	7.5	7.5
VFAS3-6040PC	4 kW	7.9	12.5	10
VFAS3-6055PC	5.5 kW	10.4	15	15
VFAS3-6075PC	7.5 kW	13.6	25	20
VFAS3-6110PC	11 kW	18.4	30	25
VFAS3-6150PC	15 kW	23.1	35	30
VFAS3-6185PC	18.5 kW	27.6	40	40
VFAS3-6220PC	22 kW	32.0	50	40
VFAS3-6300PC	30 kW	47.2	80	60
VFAS3-6370PC	37 kW	55.6	80	80
VFAS3-6450PC	45 kW	65.5	100	80
VFAS3-6550PC	55 kW	82.7	125	100
VFAS3-6750PC	75 kW	107	175	125

- This is the selection when using a Toshiba standard 4-pole motor with input of 500V-50Hz.
- Install a surge absorber on the exciting coil of a magnetic contactor (MC) and relays.
- When using an auxiliary contacts 2a type magnetic contactor (MC), use the 2a contacts in parallel to increase the liability of the contacts.
- The magnitude of the short-circuit current varies depending on the power supply capacity and wiring system conditions, so select the MCCB with the rated breaking current that matches the capacity. This table is selected assuming a general power supply capacity.
- For the influence of the leakage current, refer to [2. 4. 3] of "VF-AS3 instruction manual" (E6582062).

■ Wiring devices for 600V(575V) class ND rating

Type-Form	Applicable motor capacity	Input current (A)	Rated current (A)	
			Molded-case circuit breaker (MCCB) Earth leakage circuit breaker (ELCB)	Magnetic contactor (MC) AC-1
VFAS3-6022PC	3 HP	4.1	7.5	7.5
VFAS3-6040PC	5 HP	6.9	15	10
VFAS3-6055PC	7.5 HP	9.0	15	15
VFAS3-6075PC	10 HP	11.8	25	20
VFAS3-6110PC	15 HP	16.1	30	25
VFAS3-6150PC	20 HP	20.1	35	30
VFAS3-6185PC	25 HP	23.9	40	40
VFAS3-6220PC	30 HP	33.0	50	40
VFAS3-6300PC	40 HP	41.2	80	60
VFAS3-6370PC	50 HP	48.5	80	80
VFAS3-6450PC	60 HP	61.7	100	80
VFAS3-6550PC	75 HP	71.9	125	100
VFAS3-6750PC	100 HP	92.6	175	125

- This is the selection when using a Toshiba standard 4-pole motor with input of 575V-60Hz.
- Install a surge absorber on the exciting coil of a magnetic contactor (MC) and relays.
- When using an auxiliary contacts 2a type magnetic contactor (MC), use the 2a contacts in parallel to increase the liability of the contacts.
- The magnitude of the short-circuit current varies depending on the power supply capacity and wiring system conditions, so select the MCCB with the rated breaking current that matches the capacity. This table is selected assuming a general power supply capacity.
- For the influence of the leakage current, refer to [2. 4. 3] of "VF-AS3 instruction manual" (E6582062).

■ Wiring devices for 690V class ND rating

Type-Form	Applicable motor capacity	Input current (A)	Rated current (A)	
			Molded-case circuit breaker (MCCB) Earth leakage circuit breaker (ELCB)	Magnetic contactor (MC) AC-1
VFAS3-6022PC	3 kW	4.8	7.5	7.5
VFAS3-6030PC	4 kW	6.1	12.5	7.5
VFAS3-6040PC	5.5 kW	8.0	12.5	10
VFAS3-6055PC	7.5 kW	10.5	15	15
VFAS3-6075PC	11 kW	14.7	25	20
VFAS3-6110PC	15 kW	19.2	30	25
VFAS3-6150PC	18.5 kW	23.0	35	30
VFAS3-6185PC	22 kW	26.0	40	30
VFAS3-6220PC	30 kW	32.8	50	40
VFAS3-6300PC	37 kW	46.2	65	60
VFAS3-6370PC	45 kW	54.4	80	60
VFAS3-6450PC	55 kW	62.5	100	80
VFAS3-6550PC	75 kW	87.7	125	100
VFAS3-6750PC	90 kW	99.4	150	125

- This is the selection when using a Toshiba standard 4-pole motor with input of 690V-50Hz.
- Install a surge absorber on the exciting coil of a magnetic contactor (MC) and relays.
- When using an auxiliary contacts 2a type magnetic contactor (MC), use the 2a contacts in parallel to increase the liability of the contacts.
- The magnitude of the short-circuit current varies depending on the power supply capacity and wiring system conditions, so select the MCCB with the rated breaking current that matches the capacity. This table is selected assuming a general power supply capacity.
- For the influence of the leakage current, refer to [2. 4. 3] of "VF-AS3 instruction manual" (E6582062).

4. 2. 2 Installation of a molded-case circuit breaker (MCCB) and earth leakage circuit breaker (ELCB)

For protection of the wiring system, install a molded-case circuit breaker (MCCB) between the power supply and the inverter (primary side).

An earth leakage circuit breaker (ELCB) that is equipped with a function to shut off by detecting leakage current can be also installed. However, be cautious that an ELCB may operate improperly, because the leakage current becomes large due to the influence of a wiring method, a built-in noise filter, etc.

Because the short-circuit current is different with power supply capacity and wiring system conditions, select MCCB or ELCB depending on the inverter type and input current in the table [4. 2. 1].

Memo

- When complying with UL, CSA or Low Voltage Directive, refer to [Chapter 3].

4. 2. 3 Installation of a magnetic contactor (MC)

When installing a magnetic contactor (MC) on the primary or secondary side of the inverter, select them as follows.

■ Installation on the primary side

When the power side and the inverter need to be detached in the following cases, install a magnetic contactor (MC) between the power supply and the inverter (primary side).

Select a magnetic contactor (MC) depending on the inverter type and input current in the table [4. 2. 1].

- Thermal relay on the motor is activated
- Fault detection relay (FL) inside the inverter is activated
- Not to automatically restart at restoration of power after power lost
- When using the braking resistor (option), the thermal relay of the braking resistor is activated

To open the power circuit (primary side) when the protective function detection relay inside the inverter is activated, the molded-case circuit breaker (MCCB) with a power cutoff device can be installed instead of magnetic contactors (MC). Make sure the molded-case circuit breaker (MCCB) trips at the contact of protection detection relay. If earth leakage detector is not installed, earth leakage circuit breaker (ELCB) should be installed instead of MCCB.

A connection example for installing the primary-side magnetic contactor (MC) is shown next.

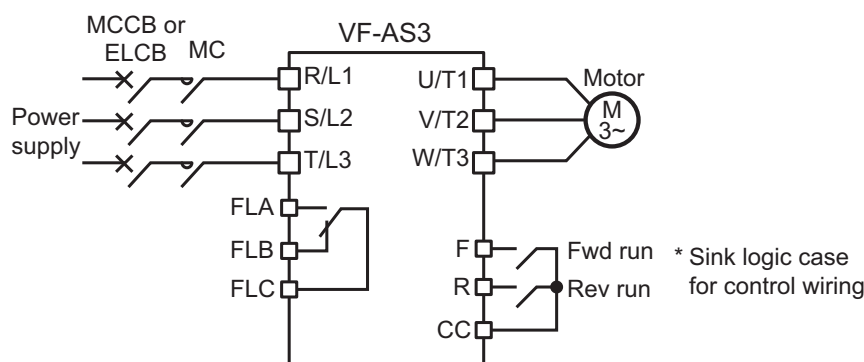

Important

- Do not run/stop the inverter by turning the magnetic contactor (MC) installed on the primary side ON/OFF. Avoid switching a magnetic contactor on the primary side more frequently than once every 1 hour. Instead, run/stop the inverter by using control terminal (ex. Digital input terminal [F] or [R]).
- Install a surge absorber on the exciting coil of a magnetic contactor (MC).

■ Installation on the secondary side

To switch the motor during the inverter is stopped, and change the motor power, a magnetic contactor (MC) can be installed between the inverter and motor (secondary side).

When operating the motor with commercial power supply by switching the circuit and not through the inverter, select a magnetic contactor (MC) with AC-3 Class and confirming to the motor rated current.

A connection example for installing the secondary-side magnetic contactor (MC) is shown next.

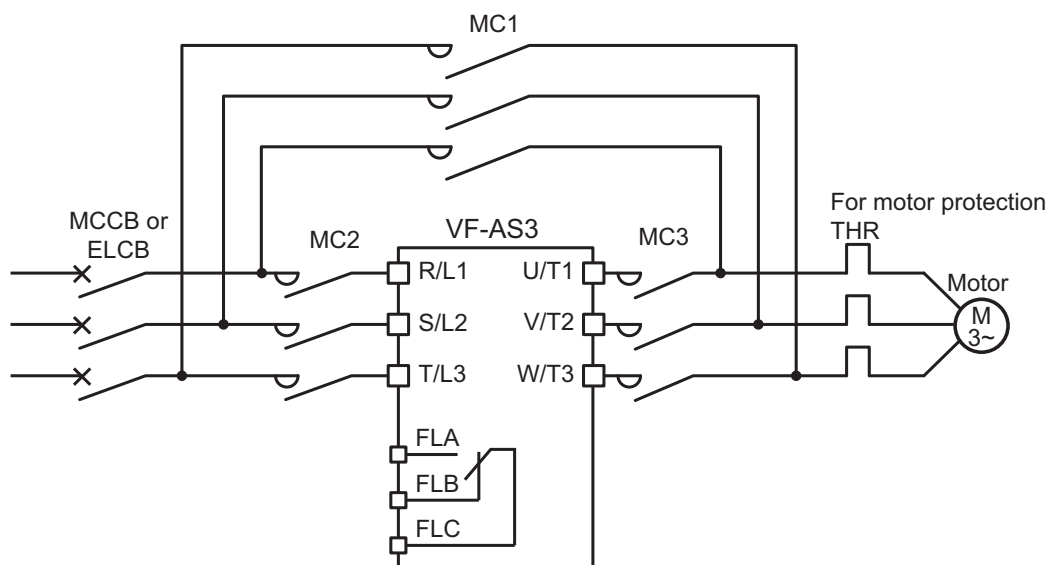

Important

- Be sure to have interlock for the commercial power supply is applied to the inverter output terminal.
- Do not turn the magnetic contactor (MC) in the secondary circuit ON/OFF during run. It can cause failure due to rush current flowing to the inverter.
- Install a surge absorber on the exciting coil of a magnetic contactor (MC).

4. 2. 4 Installation of a thermal relay (THR)

Use an electronic thermal protector of the inverter for motor overload protection. Set a motor overload protection level with a parameter according to the motor rating.

However, in the following cases, install a thermal relay (THR) between the inverter and motor (secondary side).

- Running multiple motors simultaneously with one inverter.
In this case, install a thermal relay on each motor.
- Running a motor with smaller output than applicable motor output of the standard specification
(When the motor capacity is too small to set with a parameter of the motor overload protection level).

For details on motor overload protection level, refer to [5. 2. 5] of "VF-AS3 instruction manual" (E6582062).

To give sufficient protection for the motor running in a low-speed range, the use of a motor with motor winding embedded type thermal relay is recommended.



Important

- "Thermal overload relay" is recommended, install it for each motor to be protected. "Thermal relay with CT" is not available.

4.3 External option list

Category	Product name	Specification / Ranges	Type-form
Control option	Door mounting kit	Door mounting kit for operation panel	SBP010Z
Power option	Braking resistor	Please contact to ask Toshiba distributor.	
	Input reactor		
	Output filter		
	NEMA Type 1 kit	For frame size A1Y	NEM301Z
	NEMA Type 1 kit	For frame size A2Y	NEM302Z
Others	LED extension panel	LED keypad	RKP007Z
	USB communication conversion unit	Converter between RS485 (Inverter) and USB (PC)	USB001Z
	Communication cable	for USB001Z	CAB001x x (Cable length): 1: 1m, 3: 3m, 5: 5m
	Communication cable	for door mounting kit, RKP007Z	CAB007x x (Cable length): 1: 1m, 3: 3m, 5: 5m 10: 10m (only for kit)

4.4 Insert type option

Refer to [10. 4] of "VF-AS3 instruction manual" (E6582062).

5 | Table of parameters

This chapter shows a part of basic parameters and the default settings dedicated for VF-AS3 500V / 600V (575V) / 690V class products. For detail of parameters, refer to "VF-AS3 instruction manual" (E6582062) available via the internet at "<https://www.toshiba-tips.co.jp/en/products/inverter/standard.html>".



5.1 Parameter setting

Set following basic parameters, if necessary. For detail of extended parameters, refer to [Chapter 11] of "VF-AS3 instruction manual" (E6582062).

Contents	Title	Parameter name	Adjustment range	Default setting
Determine the run command select with <CMOD> and frequency command select with <FMOD>.	CMOD	Run command select	0: Terminal 1: Operation panel, Extension panel 2: Embedded Ethernet 3: RS485 communication (connector 1) 4: RS485 communication (connector 2) 5: Communication option	0
	FMOD	Frequency command select 1	0: - 1: Terminal RR 2: Terminal RX 3: Terminal II 4: Terminal AI4 (option) 5: Terminal AI5 (option) 6 to 9: - 10: Touch wheel 1 (power off or press OK to save) 11: Touch wheel 2 (press OK to save) 12: Sr0 13 & 14: - 15: Terminal Up/Down frequency 16: Pulse train 17: High resolution pulse train (option) 18 & 19: - 20: Embedded Ethernet 21: RS485 communication (connector 1) 22: RS485 communication (connector 2) 23: Communication option	1
Set Acceleration / Deceleration time to suit the machine. <ACC> & <dEC> values are time that output frequency reach from 0 Hz to <FH> value.	ACC	Acceleration time 1	0.0 - 6000 (600.0) (s)	10.0* ¹
	dEC	Deceleration time 1	0.0 - 6000 (600.0) (s)	10.0* ¹
	FH	Maximum frequency	30.0 - 590.0 (Hz)	80.0* ²

(Continued overleaf)

(Continued)

Contents	Title	Parameter name	Adjustment range	Default setting
Set the upper and lower limit of the output frequency.	UL	Upper limit frequency	0.5 - FH (Hz)	60.0* ²
	LL	Lower limit frequency	0.0 - UL (Hz)	0.0
Select the V/f control pattern to suit the machine pattern.	Pt	V/f Pattern	0: V/f constant 1: Variable torque 2: Automatic torque boost 3: Vector control 1 4: Energy savings 5: Dynamic energy savings (for fan and pump) 6 to 12: Refer to the instruction manual E6582062	0
Adjust the electronic thermal for the motor protection.	tHrA	Motor overload protection current 1	*1	*1

*1 Depending on capacity. *2 Depending on the setup menu setting.

5.2 Parameters different from standard specifications

Title	Communication No.	Parameter name	Adjustment range	Unit	Minimum setting unit (Panel/Communication)	Default setting	Write during running	User setting	Reference (E6582062)
AUL	0094	Multi-rating select *1	0, 1, 4 - 13: - 2: ND rating (120%-60s) for 600V(575V) 3: HD rating (150%-60s) for 600V(575V) 14: ND rating (120%-60s) for 500V 15: HD rating (150%-60s) for 500V 16: ND rating (120%-60s) for 690V 17: HD rating (150%-60s) for 690V (0 after execution)	-	-	0	N		[1. 2] [5. 3. 2]
vLv	0409	Base frequency voltage 1 *1	50 - 690V	V	1/0.1	575	Y		[5. 2. 2]
F171	0171	Base frequency voltage 2 *1	50 - 690V	V	1/0.1	575	Y		[5. 2. 2]
F175	0175	Base frequency voltage 3 *1	50 - 690V	V	1/0.1	575	Y		[5. 2. 2]
F179	0179	Base frequency voltage 4 *1	50 - 690V	V	1/0.1	575	Y		[5. 2. 2]
F249	0250	DC braking carrier frequency	1.0 - 6.0: Frame size A1Y 1.0 - 4.9: Frame size A2Y	kHz	0.1/0.1	2.5	Y		[6. 8. 1]
F300	0300	Carrier frequency	1.0 - 6.0: Frame size A1Y 1.0 - 4.9: Frame size A2Y	kHz	0.1/0.1	2.5	Y		[2. 4. 1] [2. 4. 3] [6. 14]

*1: Refer to [5. 5]

5.3 Parameter setting range, default setting depending on capacity, and minimum braking resistor values

■ 500V class HD rating

Voltage class	Applicable motor	Inverter type-form	vb, F172, F176, F180	ACC, dEC, F500, F501, F510, F511, F514, F515	tHrA, F182, F183, F184		F298
	(kW)		(%)	(s)	Adjustment range	(A)	(V)
3-phase 500V	1.5	VFAS3-6022PC	6.00	10.0	0.31-3.10	3.10	264.0
	2.2	VFAS3-6030PC	6.00	10.0	0.42-4.20	4.20	264.0
	3	VFAS3-6040PC	6.00	10.0	0.54-5.40	5.40	264.0
	4	VFAS3-6055PC	4.00	10.0	0.72-7.20	7.20	264.0
	5.5	VFAS3-6075PC	4.00	10.0	0.95-9.50	9.50	264.0
	7.5	VFAS3-6110PC	4.00	10.0	1.35-13.50	13.50	264.0
	11	VFAS3-6150PC	3.00	10.0	1.80-18.00	18.00	264.0
	15	VFAS3-6185PC	3.00	30.0	2.40-24.00	24.00	264.0
	18.5	VFAS3-6220PC	3.00	30.0	2.90-29.00	29.00	264.0
	22	VFAS3-6300PC	3.00	30.0	3.40-34.00	34.00	264.0
	30	VFAS3-6370PC	3.00	30.0	4.50-45.00	45.00	264.0
	37	VFAS3-6450PC	3.00	30.0	5.5-55.0	55.0	264.0
	45	VFAS3-6550PC	3.00	30.0	6.6-66.0	66.0	264.0
55	VFAS3-6750PC	2.00	30.0	8.3-83.0	83.0	264.0	

Voltage class	Applicable motor	Inverter type-form	F300		F308	Minimum Resistor Values	F309	F316	F356	F402 F404
	(kW)		Adjustment range	(kHz)	(Ohm)	(Ohm)	(kW)	(s)	(s)	(%)
3-phase 500V	1.5	VFAS3-6022PC	1.0-6.0	2.5	100.0	12	0.24	3	0.57	4.70
	2.2	VFAS3-6030PC	1.0-6.0	2.5	100.0	12	0.24	3	0.57	3.80
	3	VFAS3-6040PC	1.0-6.0	2.5	60.0	12	0.44	3	0.87	3.80
	4	VFAS3-6055PC	1.0-6.0	2.5	60.0	12	0.44	3	0.87	4.20
	5.5	VFAS3-6075PC	1.0-6.0	2.5	60.0	12	0.44	3	0.87	2.50
	7.5	VFAS3-6110PC	1.0-6.0	2.5	60.0	12	0.44	3	1.07	2.40
	11	VFAS3-6150PC	1.0-6.0	2.5	30.0	12	0.88	3	1.07	2.20
	15	VFAS3-6185PC	1.0-6.0	2.5	30.0	12	0.88	3	1.37	2.00
	18.5	VFAS3-6220PC	1.0-6.0	2.5	15.0	12	1.76	3	1.37	1.80
	22	VFAS3-6300PC	1.0-4.9	2.5	15.0	8	1.76	3	1.37	1.50
	30	VFAS3-6370PC	1.0-4.9	2.5	15.0	8	1.76	3	1.37	1.30
	37	VFAS3-6450PC	1.0-4.9	2.5	15.0	8	1.76	3	1.37	1.10
	45	VFAS3-6550PC	1.0-4.9	2.5	8.0	5	1.76	3	1.37	1.20
55	VFAS3-6750PC	1.0-4.9	2.5	8.0	5	1.76	3	1.37	1.20	

Voltage class	Applicable motor	Inverter type-form	F412 F407	F415, F408		F416 F410	F417, F411 50 Hz setting	F456	F625	F629	F749
	(kW)		(%)	Adjustment range	(A)	(%)	(min ⁻¹)		Lower limit (%)		
3-phase 500V	1.5	VFAS3-6022PC	7.4	0.01-99.99	2.60	49	1442	100	35	35	0
	2.2	VFAS3-6030PC	5.3	0.01-99.99	3.50	42	1459	100	35	35	1
	3	VFAS3-6040PC	5.3	0.01-99.99	4.60	42	1459	100	35	35	1
	4	VFAS3-6055PC	5.0	0.01-99.99	5.80	35	1451	100	35	35	1
	5.5	VFAS3-6075PC	6.1	0.01-99.99	8.50	41	1466	100	35	35	1
	7.5	VFAS3-6110PC	5.9	0.01-99.99	11.00	38	1458	100	35	35	1
	11	VFAS3-6150PC	4.9	0.01-99.99	16.90	37	1481	100	35	35	1
	15	VFAS3-6185PC	6.4	0.01-99.99	21.80	31	1478	100	35	35	1
	18.5	VFAS3-6220PC	7.8	0.01-99.99	27.90	34	1476	100	35	35	1
	22	VFAS3-6300PC	6.8	0.01-99.99	32.80	33	1479	100	35	35	1
	30	VFAS3-6370PC	7.6	0.01-99.99	44.10	35	1483	100	35	35	2
	37	VFAS3-6450PC	7.4	0.1-999.9	54.4	33	1483	100	35	35	2
	45	VFAS3-6550PC	7.3	0.1-999.9	66.0	38	1483	100	35	35	2
55	VFAS3-6750PC	7.0	0.1-999.9	80.9	30	1480	100	35	35	2	

■ 600V(575V) class HD rating

Voltage class	Applicable motor	Inverter type-form	vb, F172, F176, F180	ACC, dEC, F500, F501, F510, F511, F514, F515	tHrA, F182, F183, F184		F298
	(HP)		(%)	(s)	Adjustment range	(A)	(V)
3-phase 600V (575V)	2	VFAS3-6022PC	6.00	10.0	0.31-3.10	3.10	264.0
	3	VFAS3-6030PC	6.00	10.0	0.42-4.20	4.20	264.0
	5	VFAS3-6055PC	4.00	10.0	0.72-7.20	7.20	264.0
	7.5	VFAS3-6075PC	4.00	10.0	0.95-9.50	9.50	264.0
	10	VFAS3-6110PC	4.00	10.0	1.35-13.50	13.50	264.0
	15	VFAS3-6150PC	3.00	10.0	1.80-18.00	18.00	264.0
	20	VFAS3-6185PC	3.00	30.0	2.40-24.00	24.00	264.0
	25	VFAS3-6220PC	3.00	30.0	2.90-29.00	29.00	264.0
	30	VFAS3-6300PC	3.00	30.0	3.40-34.00	34.00	264.0
	40	VFAS3-6370PC	3.00	30.0	4.50-45.00	45.00	264.0
	50	VFAS3-6450PC	3.00	30.0	5.5-55.0	55.0	264.0
	60	VFAS3-6550PC	3.00	30.0	6.6-66.0	66.0	264.0
75	VFAS3-6750PC	2.00	30.0	8.3-83.0	83.0	264.0	

5

Voltage class	Applicable motor	Inverter type-form	F300		F308	Minimum Resistor Values	F309	F316	F356	F402 F404
	(HP)		Adjustment range	(kHz)	(Ohm)	(Ohm)	(kW)	(s)	(s)	(%)
3-phase 600V (575V)	2	VFAS3-6022PC	1.0-6.0	2.5	100.0	12	0.24	3	0.57	4.70
	3	VFAS3-6030PC	1.0-6.0	2.5	100.0	12	0.24	3	0.57	3.80
	5	VFAS3-6055PC	1.0-6.0	2.5	60.0	12	0.44	3	0.87	4.20
	7.5	VFAS3-6075PC	1.0-6.0	2.5	60.0	12	0.44	3	0.87	2.50
	10	VFAS3-6110PC	1.0-6.0	2.5	60.0	12	0.44	3	1.07	2.40
	15	VFAS3-6150PC	1.0-6.0	2.5	30.0	12	0.88	3	1.07	2.20
	20	VFAS3-6185PC	1.0-6.0	2.5	30.0	12	0.88	3	1.37	2.00
	25	VFAS3-6220PC	1.0-6.0	2.5	15.0	12	1.76	3	1.37	1.80
	30	VFAS3-6300PC	1.0-4.9	2.5	15.0	8	1.76	3	1.37	1.50
	40	VFAS3-6370PC	1.0-4.9	2.5	15.0	8	1.76	3	1.37	1.30
	50	VFAS3-6450PC	1.0-4.9	2.5	15.0	8	1.76	3	1.37	1.10
	60	VFAS3-6550PC	1.0-4.9	2.5	8.0	5	1.76	3	1.37	1.20
75	VFAS3-6750PC	1.0-4.9	2.5	8.0	5	1.76	3	1.37	1.20	

Voltage class	Applicable motor	Inverter type-form	F412 F407	F415, F408		F416 F410	F417, F411 60 Hz setting	F456	F625	F629	F749
	(HP)		(%)	Adjustment range	(A)	(%)	(min ⁻¹)		Lower limit (%)		
3-phase 600V (575V)	2	VFAS3-6022PC	7.4	0.01-99.99	2.20	49	1730	100	30	30	0
	3	VFAS3-6030PC	5.3	0.01-99.99	3.10	42	1751	100	30	30	1
	5	VFAS3-6055PC	5.0	0.01-99.99	5.00	35	1741	100	30	30	1
	7.5	VFAS3-6075PC	6.1	0.01-99.99	7.40	41	1759	100	30	30	1
	10	VFAS3-6110PC	5.9	0.01-99.99	9.60	38	1750	100	30	30	1
	15	VFAS3-6150PC	4.9	0.01-99.99	14.70	37	1777	100	30	30	1
	20	VFAS3-6185PC	6.4	0.01-99.99	19.00	31	1774	100	30	30	1
	25	VFAS3-6220PC	7.8	0.01-99.99	24.30	34	1771	100	30	30	1
	30	VFAS3-6300PC	6.8	0.01-99.99	28.60	33	1775	100	30	30	1
	40	VFAS3-6370PC	7.6	0.01-99.99	38.40	35	1779	100	30	30	2
	50	VFAS3-6450PC	7.4	0.1-999.9	47.3	33	1779	100	30	30	2
	60	VFAS3-6550PC	7.3	0.1-999.9	58.6	38	1779	100	30	30	2
75	VFAS3-6750PC	7.0	0.1-999.9	70.4	30	1776	100	30	30	2	

■ 690V class HD rating

Voltage class	Applicable motor	Inverter type-form	vb, F172, F176, F180	ACC, dEC, F500, F501, F510, F511, F514, F515	tHrA, F182, F183, F184		F298
	(kW)		(%)	(s)	Adjustment range	(A)	(V)
3-phase 690V	2.2	VFAS3-6022PC	6.00	10.0	0.31-3.10	3.10	264.0
	3	VFAS3-6030PC	6.00	10.0	0.42-4.20	4.20	264.0
	4	VFAS3-6040PC	6.00	10.0	0.54-5.40	5.40	264.0
	5.5	VFAS3-6055PC	4.00	10.0	0.72-7.20	7.20	264.0
	7.5	VFAS3-6075PC	4.00	10.0	0.95-9.50	9.50	264.0
	11	VFAS3-6110PC	4.00	10.0	1.35-13.50	13.50	264.0
	15	VFAS3-6150PC	3.00	10.0	1.80-18.00	18.00	264.0
	18.5	VFAS3-6185PC	3.00	30.0	2.40-24.00	24.00	264.0
	22	VFAS3-6220PC	3.00	30.0	2.90-29.00	29.00	264.0
	30	VFAS3-6300PC	3.00	30.0	3.40-34.00	34.00	264.0
	37	VFAS3-6370PC	3.00	30.0	4.50-45.00	45.00	264.0
	45	VFAS3-6450PC	3.00	30.0	5.5-55.0	55.0	264.0
	55	VFAS3-6550PC	3.00	30.0	6.6-66.0	66.0	264.0
75	VFAS3-6750PC	2.00	30.0	8.3-83.0	83.0	264.0	

Voltage class	Applicable motor	Inverter type-form	F300		F308	Minimum Resistor Values	F309	F316	F356	F402 F404
	(kW)		Adjustment range	(kHz)	(Ohm)	(Ohm)	(kW)	(s)	(s)	(%)
3-phase 690V	2.2	VFAS3-6022PC	1.0-6.0	2.5	100.0	12	0.24	3	0.57	4.70
	3	VFAS3-6030PC	1.0-6.0	2.5	100.0	12	0.24	3	0.57	3.80
	4	VFAS3-6040PC	1.0-6.0	2.5	60.0	12	0.44	3	0.87	3.80
	5.5	VFAS3-6055PC	1.0-6.0	2.5	60.0	12	0.44	3	0.87	4.20
	7.5	VFAS3-6075PC	1.0-6.0	2.5	60.0	12	0.44	3	0.87	2.50
	11	VFAS3-6110PC	1.0-6.0	2.5	60.0	12	0.44	3	1.07	2.40
	15	VFAS3-6150PC	1.0-6.0	2.5	30.0	12	0.88	3	1.07	2.20
	18.5	VFAS3-6185PC	1.0-6.0	2.5	30.0	12	0.88	3	1.37	2.00
	22	VFAS3-6220PC	1.0-6.0	2.5	15.0	12	1.76	3	1.37	1.80
	30	VFAS3-6300PC	1.0-4.9	2.5	15.0	8	1.76	3	1.37	1.50
	37	VFAS3-6370PC	1.0-4.9	2.5	15.0	8	1.76	3	1.37	1.30
	45	VFAS3-6450PC	1.0-4.9	2.5	15.0	8	1.76	3	1.37	1.10
	55	VFAS3-6550PC	1.0-4.9	2.5	8.0	5	1.76	3	1.37	1.20
75	VFAS3-6750PC	1.0-4.9	2.5	8.0	5	1.76	3	1.37	1.20	

Voltage class	Applicable motor	Inverter type-form	F412 F407	F415, F408		F416 F410	F417, F411 50 Hz setting	F456	F625	F629	F749
	(kW)		(%)	Adjustment range	(A)	(%)	(min ⁻¹)		Lower limit (%)		
3-phase 690V	2.2	VFAS3-6022PC	7.4	0.01-99.99	2.50	49	1442	100	25	25	0
	3	VFAS3-6030PC	5.3	0.01-99.99	4.20	42	1459	100	25	25	1
	4	VFAS3-6040PC	5.3	0.01-99.99	5.20	42	1459	100	25	25	1
	5.5	VFAS3-6055PC	5.0	0.01-99.99	6.20	35	1451	100	25	25	1
	7.5	VFAS3-6075PC	6.1	0.01-99.99	8.00	41	1466	100	25	25	1
	11	VFAS3-6110PC	5.9	0.01-99.99	12.20	38	1458	100	25	25	1
	15	VFAS3-6150PC	4.9	0.01-99.99	15.80	37	1481	100	25	25	1
	18.5	VFAS3-6185PC	6.4	0.01-99.99	20.20	31	1478	100	25	25	1
	22	VFAS3-6220PC	7.8	0.01-99.99	23.80	34	1476	100	25	25	1
	30	VFAS3-6300PC	6.8	0.01-99.99	32.00	33	1479	100	25	25	1
	37	VFAS3-6370PC	7.6	0.01-99.99	39.40	35	1483	100	25	25	2
	45	VFAS3-6450PC	7.4	0.1-999.9	48.8	33	1483	100	25	25	2
	55	VFAS3-6550PC	7.3	0.1-999.9	58.6	38	1483	100	25	25	2
75	VFAS3-6750PC	7.0	0.1-999.9	75.1	30	1480	100	25	25	2	

■ 500V class ND rating

Voltage class	Applicable motor	Inverter type-form	vb, F172, F176, F180	ACC, dEC, F500, F501, F510, F511, F514, F515	tHrA, F182, F183, F184		F298
	(kW)		(%)	(s)	Adjustment range	(A)	(V)
3-phase 690V	2.2	VFAS3-6022PC	6.00	10.0	0.42-4.20	4.20	264.0
	3	VFAS3-6030PC	6.00	10.0	0.54-5.40	5.40	264.0
	4	VFAS3-6040PC	4.00	10.0	0.72-7.20	7.20	264.0
	5.5	VFAS3-6055PC	4.00	10.0	0.95-9.50	9.50	264.0
	7.5	VFAS3-6075PC	4.00	10.0	1.35-13.50	13.50	264.0
	11	VFAS3-6110PC	3.00	10.0	1.80-18.00	18.00	264.0
	15	VFAS3-6150PC	3.00	30.0	2.40-24.00	24.00	264.0
	18.5	VFAS3-6185PC	3.00	30.0	2.90-29.00	29.00	264.0
	22	VFAS3-6220PC	3.00	30.0	3.40-34.00	34.00	264.0
	30	VFAS3-6300PC	3.00	30.0	4.50-45.00	45.00	264.0
	37	VFAS3-6370PC	3.00	30.0	5.50-55.00	55.00	264.0
	45	VFAS3-6450PC	3.00	30.0	6.6-66.0	66.0	264.0
	55	VFAS3-6550PC	2.00	30.0	8.3-83.0	83.0	264.0
75	VFAS3-6750PC	2.00	60.0	10.8-108.0	108.0	264.0	

Voltage class	Applicable motor	Inverter type-form	F300		F308	Minimum Resistor Values	F309	F316	F356	F402 F404
	(kW)		Adjustment range	(kHz)	(Ohm)	(Ohm)	(kW)	(s)	(s)	(%)
3-phase 690V	2.2	VFAS3-6022PC	1.0-6.0	2.5	100.0	12	0.24	3	0.57	3.80
	3	VFAS3-6030PC	1.0-6.0	2.5	60.0	12	0.44	3	0.87	3.80
	4	VFAS3-6040PC	1.0-6.0	2.5	60.0	12	0.44	3	0.87	4.20
	5.5	VFAS3-6055PC	1.0-6.0	2.5	60.0	12	0.44	3	0.87	2.50
	7.5	VFAS3-6075PC	1.0-6.0	2.5	60.0	12	0.44	3	1.07	2.40
	11	VFAS3-6110PC	1.0-6.0	2.5	30.0	12	0.88	3	1.07	2.20
	15	VFAS3-6150PC	1.0-6.0	2.5	30.0	12	0.88	3	1.37	2.00
	18.5	VFAS3-6185PC	1.0-6.0	2.5	15.0	12	1.76	3	1.37	1.80
	22	VFAS3-6220PC	1.0-6.0	2.5	15.0	12	1.76	3	1.37	1.50
	30	VFAS3-6300PC	1.0-4.9	2.5	15.0	8	1.76	3	1.37	1.30
	37	VFAS3-6370PC	1.0-4.9	2.5	15.0	8	1.76	3	1.37	1.10
	45	VFAS3-6450PC	1.0-4.9	2.5	8.0	8	1.76	3	1.37	1.20
	55	VFAS3-6550PC	1.0-4.9	2.5	8.0	5	1.76	3	1.37	1.20
75	VFAS3-6750PC	1.0-4.9	2.5	8.0	5	1.76	3	1.37	1.30	

Voltage class	Applicable motor	Inverter type-form	F412 F407	F415, F408		F416 F410	F417, F411 50 Hz setting	F456	F625	F629	F749
	(kW)		(%)	Adjustment range	(A)	(%)	(min ⁻¹)		Lower limit (%)		
3-phase 690V	2.2	VFAS3-6022PC	5.3	0.01-99.99	3.50	42	1459	100	35	35	1
	3	VFAS3-6030PC	5.3	0.01-99.99	4.60	42	1459	100	35	35	1
	4	VFAS3-6040PC	5.0	0.01-99.99	5.80	35	1451	100	35	35	1
	5.5	VFAS3-6055PC	6.1	0.01-99.99	8.50	41	1466	100	35	35	1
	7.5	VFAS3-6075PC	5.9	0.01-99.99	11.00	38	1458	100	35	35	1
	11	VFAS3-6110PC	4.9	0.01-99.99	16.90	37	1481	100	35	35	1
	15	VFAS3-6150PC	6.4	0.01-99.99	21.80	31	1478	100	35	35	1
	18.5	VFAS3-6185PC	7.8	0.01-99.99	27.90	34	1476	100	35	35	1
	22	VFAS3-6220PC	6.8	0.01-99.99	32.80	33	1479	100	35	35	1
	30	VFAS3-6300PC	7.6	0.01-99.99	44.10	35	1483	100	35	35	2
	37	VFAS3-6370PC	7.4	0.01-99.99	54.40	33	1483	100	35	35	2
	45	VFAS3-6450PC	7.3	0.1-999.9	67.4	38	1483	100	35	35	2
	55	VFAS3-6550PC	7.0	0.1-999.9	80.9	30	1480	100	35	35	2
75	VFAS3-6750PC	5.7	0.1-999.9	104.0	26	1484	100	35	35	2	

■ 600V(575V) class ND rating

Voltage class	Applicable motor	Inverter type-form	vb, F172, F176, F180	ACC, dEC, F500, F501, F510, F511, F514, F515	tHrA, F182, F183, F184		F298
	(HP)		(%)	(s)	Adjustment range	(A)	(V)
3-phase 600V (575V)	3	VFAS3-6022PC	6.00	10.0	0.42-4.20	4.20	264.0
	5	VFAS3-6040PC	4.00	10.0	0.72-7.20	7.20	264.0
	7.5	VFAS3-6055PC	4.00	10.0	0.95-9.50	9.50	264.0
	10	VFAS3-6075PC	4.00	10.0	1.35-13.50	13.50	264.0
	15	VFAS3-6110PC	3.00	10.0	1.80-18.00	18.00	264.0
	20	VFAS3-6150PC	3.00	30.0	2.40-24.00	24.00	264.0
	25	VFAS3-6185PC	3.00	30.0	2.90-29.00	29.00	264.0
	30	VFAS3-6220PC	3.00	30.0	3.40-34.00	34.00	264.0
	40	VFAS3-6300PC	3.00	30.0	4.50-45.00	45.00	264.0
	50	VFAS3-6370PC	3.00	30.0	5.50-55.00	55.00	264.0
	60	VFAS3-6450PC	3.00	30.0	6.6-66.0	66.0	264.0
	75	VFAS3-6550PC	2.00	30.0	8.3-83.0	83.0	264.0
100	VFAS3-6750PC	2.00	60.0	10.8-108.0	108.0	264.0	

Voltage class	Applicable motor	Inverter type-form	F300		F308	Minimum Resistor Values	F309	F316	F356	F402 F404
	(HP)		Adjustment range	(kHz)	(Ohm)	(Ohm)	(kW)	(s)	(s)	(%)
3-phase 600V (575V)	3	VFAS3-6022PC	1.0-6.0	2.5	100.0	12	0.24	3	0.57	3.80
	5	VFAS3-6040PC	1.0-6.0	2.5	60.0	12	0.44	3	0.87	4.20
	7.5	VFAS3-6055PC	1.0-6.0	2.5	60.0	12	0.44	3	0.87	2.50
	10	VFAS3-6075PC	1.0-6.0	2.5	60.0	12	0.44	3	1.07	2.40
	15	VFAS3-6110PC	1.0-6.0	2.5	30.0	12	0.88	3	1.07	2.20
	20	VFAS3-6150PC	1.0-6.0	2.5	30.0	12	0.88	3	1.37	2.00
	25	VFAS3-6185PC	1.0-6.0	2.5	15.0	12	1.76	3	1.37	1.80
	30	VFAS3-6220PC	1.0-6.0	2.5	15.0	12	1.76	3	1.37	1.50
	40	VFAS3-6300PC	1.0-4.9	2.5	15.0	8	1.76	3	1.37	1.30
	50	VFAS3-6370PC	1.0-4.9	2.5	15.0	8	1.76	3	1.37	1.10
	60	VFAS3-6450PC	1.0-4.9	2.5	8.0	8	1.76	3	1.37	1.20
	75	VFAS3-6550PC	1.0-4.9	2.5	8.0	5	1.76	3	1.37	1.20
100	VFAS3-6750PC	1.0-4.9	2.5	8.0	5	1.76	3	1.37	1.30	

Voltage class	Applicable motor	Inverter type-form	F412 F407	F415, F408		F416 F410	F417, F411 60 Hz setting	F456	F625	F629	F749
	(HP)		(%)	Adjustment range	(A)	(%)	(min ⁻¹)		Lower limit (%)		
3-phase 600V (575V)	3	VFAS3-6022PC	5.3	0.01-99.99	3.10	42	1751	100	30	30	1
	5	VFAS3-6040PC	5.0	0.01-99.99	5.00	35	1741	100	30	30	1
	7.5	VFAS3-6055PC	6.1	0.01-99.99	7.40	41	1759	100	30	30	1
	10	VFAS3-6075PC	5.9	0.01-99.99	9.60	38	1750	100	30	30	1
	15	VFAS3-6110PC	4.9	0.01-99.99	14.70	37	1777	100	30	30	1
	20	VFAS3-6150PC	6.4	0.01-99.99	19.00	31	1774	100	30	30	1
	25	VFAS3-6185PC	7.8	0.01-99.99	24.30	34	1771	100	30	30	1
	30	VFAS3-6220PC	6.8	0.01-99.99	28.60	33	1775	100	30	30	1
	40	VFAS3-6300PC	7.6	0.01-99.99	38.40	35	1779	100	30	30	2
	50	VFAS3-6370PC	7.4	0.01-99.99	47.30	33	1779	100	30	30	2
	60	VFAS3-6450PC	7.3	0.1-999.9	58.6	38	1779	100	30	30	2
	75	VFAS3-6550PC	7.0	0.1-999.9	70.4	30	1776	100	30	30	2
100	VFAS3-6750PC	5.7	0.1-999.9	90.2	26	1781	100	30	30	2	

■ 690V class ND rating

Voltage class	Applicable motor	Inverter type-form	vb, F172, F176, F180	ACC, dEC, F500, F501, F510, F511, F514, F515	tHrA, F182, F183, F184		F298
	(kW)		(%)	(s)	Adjustment range	(A)	(V)
3-phase 690V	3	VFAS3-6022PC	6.00	10.0	0.42-4.20	4.20	264.0
	4	VFAS3-6030PC	6.00	10.0	0.54-5.40	5.40	264.0
	5.5	VFAS3-6040PC	4.00	10.0	0.72-7.20	7.20	264.0
	7.5	VFAS3-6055PC	4.00	10.0	0.95-9.50	9.50	264.0
	11	VFAS3-6075PC	4.00	10.0	1.35-13.50	13.50	264.0
	15	VFAS3-6110PC	3.00	10.0	1.80-18.00	18.00	264.0
	18.5	VFAS3-6150PC	3.00	30.0	2.40-24.00	24.00	264.0
	22	VFAS3-6185PC	3.00	30.0	2.90-29.00	29.00	264.0
	30	VFAS3-6220PC	3.00	30.0	3.40-34.00	34.00	264.0
	37	VFAS3-6300PC	3.00	30.0	4.50-45.00	45.00	264.0
	45	VFAS3-6370PC	3.00	30.0	5.50-55.00	55.00	264.0
	55	VFAS3-6450PC	3.00	30.0	6.6-66.0	66.0	264.0
	75	VFAS3-6550PC	2.00	30.0	8.3-83.0	83.0	264.0
90	VFAS3-6750PC	2.00	60.0	10.8-108.0	108.0	264.0	

Voltage class	Applicable motor	Inverter type-form	F300		F308	Minimum Resistor Values	F309	F316	F356	F402 F404
	(kW)		Adjustment range	(kHz)	(Ohm)	(Ohm)	(kW)	(s)	(s)	(%)
3-phase 690V	3	VFAS3-6022PC	1.0-6.0	2.5	100.0	12	0.24	3	0.57	3.80
	4	VFAS3-6030PC	1.0-6.0	2.5	60.0	12	0.44	3	0.87	3.80
	5.5	VFAS3-6040PC	1.0-6.0	2.5	60.0	12	0.44	3	0.87	4.20
	7.5	VFAS3-6055PC	1.0-6.0	2.5	60.0	12	0.44	3	0.87	2.50
	11	VFAS3-6075PC	1.0-6.0	2.5	60.0	12	0.44	3	1.07	2.40
	15	VFAS3-6110PC	1.0-6.0	2.5	30.0	12	0.88	3	1.07	2.20
	18.5	VFAS3-6150PC	1.0-6.0	2.5	30.0	12	0.88	3	1.37	2.00
	22	VFAS3-6185PC	1.0-6.0	2.5	15.0	12	1.76	3	1.37	1.80
	30	VFAS3-6220PC	1.0-6.0	2.5	15.0	12	1.76	3	1.37	1.50
	37	VFAS3-6300PC	1.0-4.9	2.5	15.0	8	1.76	3	1.37	1.30
	45	VFAS3-6370PC	1.0-4.9	2.5	15.0	8	1.76	3	1.37	1.10
	55	VFAS3-6450PC	1.0-4.9	2.5	8.0	8	1.76	3	1.37	1.20
	75	VFAS3-6550PC	1.0-4.9	2.5	8.0	5	1.76	3	1.37	1.20
90	VFAS3-6750PC	1.0-4.9	2.5	8.0	5	1.76	3	1.37	1.30	

Voltage class	Applicable motor	Inverter type-form	F412 F407	F415, F408		F416 F410	F417, F411 50 Hz setting	F456	F625	F629	F749
	(kW)		(%)	Adjustment range	(A)	(%)	(min ⁻¹)		Lower limit (%)		
3-phase 690V	3	VFAS3-6022PC	5.3	0.01-99.99	4.20	42	1459	100	25	25	1
	4	VFAS3-6030PC	5.3	0.01-99.99	5.20	42	1459	100	25	25	1
	5.5	VFAS3-6040PC	5.0	0.01-99.99	6.20	35	1451	100	25	25	1
	7.5	VFAS3-6055PC	6.1	0.01-99.99	8.00	41	1466	100	25	25	1
	11	VFAS3-6075PC	5.9	0.01-99.99	12.20	38	1458	100	25	25	1
	15	VFAS3-6110PC	4.9	0.01-99.99	15.80	37	1481	100	25	25	1
	18.5	VFAS3-6150PC	6.4	0.01-99.99	20.20	31	1478	100	25	25	1
	22	VFAS3-6185PC	7.8	0.01-99.99	23.80	34	1476	100	25	25	1
	30	VFAS3-6220PC	6.8	0.01-99.99	32.00	33	1479	100	25	25	1
	37	VFAS3-6300PC	7.6	0.01-99.99	39.40	35	1483	100	25	25	2
	45	VFAS3-6370PC	7.4	0.01-99.99	48.80	33	1483	100	25	25	2
	55	VFAS3-6450PC	7.3	0.1-999.9	58.6	38	1483	100	25	25	2
	75	VFAS3-6550PC	7.0	0.1-999.9	75.1	30	1480	100	25	25	2
90	VFAS3-6750PC	5.7	0.1-999.9	92.6	26	1484	100	25	25	2	

5.4 Setup menu

Parameter title	Function	Mainly North America	Mainly Asia	Mainly Europe	China	Japan
FH	Maximum frequency (Hz)	80.0	80.0	80.0	80.0	80.0
F307	Supply voltage compensation	2	2	2	2	3
F319	Regenerative over-flux upper limit (%)	120	120	120	140	140
F411, F417	Motor rated speed (min-1)	*1	*1	*1	*1	*1
vLv, F171, F175, F179	Base frequency Voltage (V)	575	575	575	575	575
vL, UL, F170, F174, F178, F204, F213, F219, F225, F231, F237, F330, F335, F364, F365, F367, F370, F426, F428, F814, A220, A229, A230, A316, A317, A319, A322, A486, A487, A538	Frequency (Hz)	60.0	60.0	60.0	60.0	60.0
F606, F643	Frequency (max of set value) (Hz)	60.0	60.0	60.0	60.0	60.0
F405, F406, A339	Motor rated Capacity (kW)	4.0	4.0	4.0	4.0	3.7
F243	End frequency	0.0	0.0	0.0	0.0	0.1
F681	Terminal FM switching	2	2	2	2	0
F704	Reference Website	0	1	1	1	1

*1 Depending on the region and the capacity. Refer to [5. 3].

5.5 Multi-rating select

HD-575V-60Hz is set in default setting. For ND or 500V/690V motor use, before starting operation, please set parameter <AUL: Multi-rating select>.

<AUL> setting		<AUL>=2	<AUL>=3	<AUL>=14	<AUL>=15	<AUL>=16	<AUL>=17
HD/ND		ND	HD	ND	HD	ND	HD
Voltage class		600V (575V)	600V (575V)	500V	500V	690V	690V
Parameter title	Function	setting value					
vLv, F171, F175, F179	Base frequency Voltage (V)	575	575	500	500	690	690
vL, UL, F170, F174, F178, F204, F213, F219, F225, F231, F237, F330, F335, F364, F365, F367, F370, F426, F428, F814, A220, A229, A230, A316, A317, A319, A322, A486, A487, A538	Frequency (Hz)	50.0	50.0	60.0	60.0	50.0	50.0
F606, F643	Frequency (max of set value) (Hz)	50.0	50.0	60.0	60.0	50.0	50.0

*1 Depending on the region and the capacity. Refer to [5. 3].

6 Specifications

I

II

1

2

3

4

5

6

7

8

In this chapter, the inverter's model and type, standard specification, outside dimensions, and approx. mass are described.

6.1 Model and main standard specification

■ Standard specification depending on model

<500 V class: HD rating>

Item		Specification								
Voltage class		500V class								
Frame size		A1Y								
Applicable motor (kW)		1.5	2.2	3	4	5.5	7.5	11	15	18.5
Rating	Type	VFAS3-								
	Form	6022PC	6030PC	6040PC	6055PC	6075PC	6110PC	6150PC	6185PC	6220PC
	Output capacity (kVA) ^{*1}	2.7	3.6	4.7	6.2	8.2	12	16	21	25
	Output current (A) ^{*2}	3.1	4.2	5.4	7.2	9.5	13.5	18	24	29
	Output voltage	Three-phase 500V to 690V (The maximum output voltage is equal to the input supply voltage.)								
	Overload current rating	150%-1 minute								
Electrical braking	Dynamic braking circuit	Built-in								
	Dynamic braking resistor	External braking resistor (Optional)								
Power supply	Voltage-frequency	3-phase 500 V to 690 V - 50/60 Hz								
	Allowable fluctuation	Voltage 425V to 759V ^{*3} , Frequency \pm 5%								
	Required power supply capacity (kVA) ^{*4}	3.2	4.5	5.9	7.5	9.9	13	18	22	26
Degree of protection (IEC60529)		IP00								
Enclosure rating (UL50)		Open								
Cooling method		Forced air-cooled								
Cooling fan noise (dB) Reference value ^{*5}		58	58	58	58	58	58	58	58	58
Color		RAL7016								
EMC filter (IEC61800-3)		Category C3 (25m or less)								
DC reactor		Built-in								

*1. Capacity is calculated at 500 V for the 500 V class.

*2. Indicates rated output current setting when the PWM carrier frequency (parameter F300) is 2.5 kHz.

*3. When the input voltage is below rating, the output current may be restricted or increased depending on application.

*4. Required power supply capacity varies with the value of the power supply side inverter impedance (including those of the input reactor and wires).

*5. These acoustic noise values are not guaranteed because they are just reference values.

Item		Specification				
Voltage class		500V class				
Frame size		A2Y				
Applicable motor (kW)		22	30	37	45	55
Rating	Type	VFAS3-				
	Form	6300PC	6370PC	6450PC	6550PC	6750PC
	Output capacity (kVA) ^{*1}	29	39	48	57	72
	Output current (A) ^{*2}	34	45	55	66	83
	Output voltage	Three-phase 500V to 690V (The maximum output voltage is equal to the input supply voltage.)				
	Overload current rating	150%-1 minute				
Electrical braking	Dynamic braking circuit	Built-in				
	Dynamic braking resistor	External braking resistor (Optional)				
Power supply	Voltage-frequency	3-phase 500 V to 690 V - 50/60 Hz				
	Allowable fluctuation	Voltage 425V to 759V ^{*3} , Frequency \pm 5%				
	Required power supply capacity (kVA) ^{*4}	36	45	53	68	79
Degree of protection (IEC60529)		IP00				
Enclosure rating (UL50)		Open				
Cooling method		Forced air-cooled				
Cooling fan noise (dB) Reference value ^{*5}		56	56	56	56	56
Color		RAL7016				
EMC filter (IEC61800-3)		Category C3 (25m or less)				
DC reactor		Built-in				

*1. Capacity is calculated at 500 V for the 500 V class.

*2. Indicates rated output current setting when the PWM carrier frequency (parameter F300) is 2.5 kHz.

*3. When the input voltage is below rating, the output current may be restricted or increased depending on application.

*4. Required power supply capacity varies with the value of the power supply side inverter impedance (including those of the input reactor and wires).

*5. These acoustic noise values are not guaranteed because they are just reference values.

<600 V (575 V) class: HD rating>

Item		Specification							
Voltage class		600V(575V) class							
Frame size		A1Y							
Applicable motor (HP)		2	3	5	7.5	10	15	20	25
Rating	Type	VFAS3-							
	Form	6022PC	6030PC	6055PC	6075PC	6110PC	6150PC	6185PC	6220PC
	Output capacity (kVA) ^{*1}	3.1	4.2	7.2	9.5	13	18	24	29
	Output current (A) ^{*2}	3.1	4.2	7.2	9.5	13.5	18	24	29
	Output voltage	Three-phase 500V to 600V (The maximum output voltage is equal to the input supply voltage.)							
	Overload current rating	150%-1 minute							
Electrical braking	Dynamic braking circuit	Built-in							
	Dynamic braking resistor	External braking resistor (Optional)							
Power supply	Voltage-frequency	3-phase 500 V to 600 V - 50/60 Hz							
	Allowable fluctuation	Voltage 425V to 660V ^{*3} , Frequency \pm 5%							
	Required power supply capacity (kVA) ^{*4}	3.3	4.5	7.5	9.9	13	18	22	26
Degree of protection (IEC60529)		IP00							
Enclosure rating (UL50)		Open							
Cooling method		Forced air-cooled							
Cooling fan noise (dB) Reference value ^{*5}		58	58	58	58	58	58	58	58
Color		RAL7016							
EMC filter (IEC61800-3)		Category C3 (25m or less)							
DC reactor		Built-in							

*1. Capacity is calculated at 600V for the 600V(575V) class.

*2. Indicates rated output current setting when the PWM carrier frequency (parameter F300) is 2.5 kHz.

*3. When the input voltage is below rating, the output current may be restricted or increased depending on application.

*4. Required power supply capacity varies with the value of the power supply side inverter impedance (including those of the input reactor and wires).

*5. These acoustic noise values are not guaranteed because they are just reference values.

Item		Specification				
Voltage class		600V(575V) class				
Frame size		A2Y				
Applicable motor (HP)		30	40	50	60	75
Rating	Type	VFAS3-				
	Form	6300PC	6370PC	6450PC	6550PC	6750PC
	Output capacity (kVA) ^{*1}	34	45	55	66	83
	Output current (A) ^{*2}	34	45	55	66	83
	Output voltage	Three-phase 500V to 600V (The maximum output voltage is equal to the input supply voltage.)				
	Overload current rating	150%-1 minute				
Electrical braking	Dynamic braking circuit	Built-in				
	Dynamic braking resistor	External braking resistor (Optional)				
Power supply	Voltage-frequency	3-phase 500 V to 600 V - 50/60 Hz				
	Allowable fluctuation	Voltage 425V to 660V ^{*3} , Frequency $\pm 5\%$				
	Required power supply capacity (kVA) ^{*4}	36	45	53	68	79
Degree of protection (IEC60529)		IP00				
Enclosure rating (UL50)		Open				
Cooling method		Forced air-cooled				
Cooling fan noise (dB) Reference value ^{*5}		56	56	56	56	56
Color		RAL7016				
EMC filter (IEC61800-3)		Category C3 (25m or less)				
DC reactor		Built-in				

*1. Capacity is calculated at 600V for the 600V(575V) class.

*2. Indicates rated output current setting when the PWM carrier frequency (parameter F300) is 2.5 kHz.

*3. When the input voltage is below rating, the output current may be restricted or increased depending on application.

*4. Required power supply capacity varies with the value of the power supply side inverter impedance (including those of the input reactor and wires).

*5. These acoustic noise values are not guaranteed because they are just reference values.

<690 V class: HD rating>

Item		Specification								
Voltage class		690V class								
Frame size		A1Y								
Applicable motor (kW)		2.2	3	4	5.5	7.5	11	15	18.5	22
Rating	Type	VFAS3-								
	Form	6022PC	6030PC	6040PC	6055PC	6075PC	6110PC	6150PC	6185PC	6220PC
	Output capacity (kVA) ^{*1}	3.7	5.0	6.5	8.6	11	16	22	29	35
	Output current (A) ^{*2}	3.1	4.2	5.4	7.2	9.5	13.5	18	24	29
	Output voltage	Three-phase 500V to 690V (The maximum output voltage is equal to the input supply voltage.)								
	Overload current rating	150%-1 minute								
Electrical braking	Dynamic braking circuit	Built-in								
	Dynamic braking resistor	External braking resistor (Optional)								
Power supply	Voltage-frequency	3-phase 500 V to 690 V - 50/60 Hz								
	Allowable fluctuation	Voltage 425V to 759V ^{*3} , Frequency $\pm 5\%$								
	Required power supply capacity (kVA) ^{*4}	4.8	6.3	8.0	11	14	19	25	30	34
Degree of protection (IEC60529)		IP00								
Enclosure rating (UL50)		Open								
Cooling method		Forced air-cooled								
Cooling fan noise (dB) Reference value ^{*5}		58	58	58	58	58	58	58	58	58
Color		RAL7016								
EMC filter (IEC61800-3)		Category C3 (25m or less)								
DC reactor		Built-in								

*1. Capacity is calculated at 690 V for the 690 V class.

*2. Indicates rated output current setting when the PWM carrier frequency (parameter F300) is 2.5 kHz.

*3. When the input voltage is below rating, the output current may be restricted or increased depending on application.

*4. Required power supply capacity varies with the value of the power supply side inverter impedance (including those of the input reactor and wires).

*5. These acoustic noise values are not guaranteed because they are just reference values.

Item		Specification				
Voltage class		690V class				
Frame size		A2Y				
Applicable motor (kW)		30	37	45	55	75
Rating	Type	VFAS3-				
	Form	6300PC	6370PC	6450PC	6550PC	6750PC
	Output capacity (kVA) ^{*1}	41	54	66	79	99
	Output current (A) ^{*2}	34	45	55	66	83
	Output voltage	Three-phase 500V to 690V (The maximum output voltage is equal to the input supply voltage.)				
	Overload current rating	150%-1 minute				
Electrical braking	Dynamic braking circuit	Built-in				
	Dynamic braking resistor	External braking resistor (Optional)				
Power supply	Voltage-frequency	3-phase 500 V to 690 V - 50/60 Hz				
	Allowable fluctuation	Voltage 425V to 759V ^{*3} , Frequency \pm 5%				
	Required power supply capacity (kVA) ^{*4}	51	61	71	90	115
Degree of protection (IEC60529)		IP00				
Enclosure rating (UL50)		Open				
Cooling method		Forced air-cooled				
Cooling fan noise (dB) Reference value ^{*5}		56	56	56	56	56
Color		RAL7016				
EMC filter (IEC61800-3)		Category C3 (25m or less)				
DC reactor		Built-in				

*1. Capacity is calculated at 690 V for the 690 V class.

*2. Indicates rated output current setting when the PWM carrier frequency (parameter F300) is 2.5 kHz.

*3. When the input voltage is below rating, the output current may be restricted or increased depending on application.

*4. Required power supply capacity varies with the value of the power supply side inverter impedance (including those of the input reactor and wires).

*5. These acoustic noise values are not guaranteed because they are just reference values.

<500 V class: ND rating>

Item		Specification								
Voltage class		500V class								
Frame size		A1Y								
Applicable motor (kW)		2.2	3	4	5.5	7.5	11	15	18.5	22
Rating	Type	VFAS3-								
	Form	6022PC	6030PC	6040PC	6055PC	6075PC	6110PC	6150PC	6185PC	6220PC
	Output capacity (kVA) ^{*1}	3.6	4.7	6.2	8.2	12	16	21	25	29
	Output current (A) ^{*2}	4.2	5.4	7.2	9.5	13.5	18	24	29	34
	Output voltage	Three-phase 500V to 690V (The maximum output voltage is equal to the input supply voltage.)								
	Overload current rating	120%-1 minute								
Electrical braking	Dynamic braking circuit	Built-in								
	Dynamic braking resistor	External braking resistor (Optional)								
Power supply	Voltage-frequency	3-phase 500 V to 690 V - 50/60 Hz								
	Allowable fluctuation	Voltage 425V to 759V ^{*3} , Frequency $\pm 5\%$								
	Required power supply capacity (kVA) ^{*4}	4.3	5.6	7.1	9.4	12	17	21	25	29
Degree of protection (IEC60529)		IP00								
Enclosure rating (UL50)		Open								
Cooling method		Forced air-cooled								
Cooling fan noise (dB) Reference value ^{*5}		58	58	58	58	58	58	58	58	58
Color		RAL7016								
EMC filter (IEC61800-3)		Category C3 (25m or less)								
DC reactor		Built-in								

*1. Capacity is calculated at 500 V for the 500 V class.

*2. Indicates rated output current setting when the PWM carrier frequency (parameter F300) is 2.5 kHz.

*3. When the input voltage is below rating, the output current may be restricted or increased depending on application.

*4. Required power supply capacity varies with the value of the power supply side inverter impedance (including those of the input reactor and wires).

*5. These acoustic noise values are not guaranteed because they are just reference values.

Item		Specification				
Voltage class		500V class				
Frame size		A2Y				
Applicable motor (kW)		30	37	45	55	75
Rating	Type	VFAS3-				
	Form	6300PC	6370PC	6450PC	6550PC	6750PC
	Output capacity (kVA) ^{*1}	39	48	57	72	94
	Output current (A) ^{*2}	45	55	66	83	108
	Output voltage	Three-phase 500V to 690V (The maximum output voltage is equal to the input supply voltage.)				
	Overload current rating	120%-1 minute				
Electrical braking	Dynamic braking circuit	Built-in				
	Dynamic braking resistor	External braking resistor (Optional)				
Power supply	Voltage-frequency	3-phase 500 V to 690 V - 50/60 Hz				
	Allowable fluctuation	Voltage 425V to 759V ^{*3} , Frequency \pm 5%				
	Required power supply capacity (kVA) ^{*4}	43	51	60	75	98
Degree of protection (IEC60529)		IP00				
Enclosure rating (UL50)		Open				
Cooling method		Forced air-cooled				
Cooling fan noise (dB) Reference value ^{*5}		56	56	56	56	56
Color		RAL7016				
EMC filter (IEC61800-3)		Category C3 (25m or less)				
DC reactor		Built-in				

*1. Capacity is calculated at 500 V for the 500 V class.

*2. Indicates rated output current setting when the PWM carrier frequency (parameter F300) is 2.5 kHz.

*3. When the input voltage is below rating, the output current may be restricted or increased depending on application.

*4. Required power supply capacity varies with the value of the power supply side inverter impedance (including those of the input reactor and wires).

*5. These acoustic noise values are not guaranteed because they are just reference values.

<600 V (575 V) class: ND rating>

Item		Specification							
Voltage class		600V(575V) class							
Frame size		A1Y							
Applicable motor (HP)		3	5	7.5	10	15	20	25	30
Rating	Type	VFAS3-							
	Form	6022PC	6040PC	6055PC	6075PC	6110PC	6150PC	6185PC	6220PC
	Output capacity (kVA) ^{*1}	4.2	7.2	9.5	13	18	24	29	34
	Output current (A) ^{*2}	4.2	7.2	9.5	13.5	18	24	29	34
	Output voltage	Three-phase 500V to 600V (The maximum output voltage is equal to the input supply voltage.)							
	Overload current rating	120%-1 minute							
Electrical braking	Dynamic braking circuit	Built-in							
	Dynamic braking resistor	External braking resistor (Optional)							
Power supply	Voltage-frequency	3-phase 500 V to 600 V - 50/60 Hz							
	Allowable fluctuation	Voltage 425V to 660V ^{*3} , Frequency \pm 5%							
	Required power supply capacity (kVA) ^{*4}	4.3	7.2	9.5	12	17	21	25	29
Degree of protection (IEC60529)		IP00							
Enclosure rating (UL50)		Open							
Cooling method		Forced air-cooled							
Cooling fan noise (dB) Reference value ^{*5}		58	58	58	58	58	58	58	58
Color		RAL7016							
EMC filter (IEC61800-3)		Category C3 (25m or less)							
DC reactor		Built-in							

*1. Capacity is calculated at 600V for the 600V(575V) class.

*2. Indicates rated output current setting when the PWM carrier frequency (parameter F300) is 2.5 kHz.

*3. When the input voltage is below rating, the output current may be restricted or increased depending on application.

*4. Required power supply capacity varies with the value of the power supply side inverter impedance (including those of the input reactor and wires).

*5. These acoustic noise values are not guaranteed because they are just reference values.

Item		Specification				
Voltage class		600V(575V) class				
Frame size		A2Y				
Applicable motor (HP)		40	50	60	75	100
Rating	Type	VFAS3-				
	Form	6300PC	6370PC	6450PC	6550PC	6750PC
	Output capacity (kVA) ^{*1}	45	55	66	83	108
	Output current (A) ^{*2}	45	55	66	83	108
	Output voltage	Three-phase 500V to 600V (The maximum output voltage is equal to the input supply voltage.)				
	Overload current rating	120%-1 minute				
Electrical braking	Dynamic braking circuit	Built-in				
	Dynamic braking resistor	External braking resistor (Optional)				
Power supply	Voltage-frequency	3-phase 500 V to 600 V - 50/60 Hz				
	Allowable fluctuation	Voltage 425V to 660V ^{*3} , Frequency \pm 5%				
	Required power supply capacity (kVA) ^{*4}	43	51	59	75	97
Degree of protection (IEC60529)		IP00				
Enclosure rating (UL50)		Open				
Cooling method		Forced air-cooled				
Cooling fan noise (dB) Reference value ^{*5}		56	56	56	56	56
Color		RAL7016				
EMC filter (IEC61800-3)		Category C3 (25m or less)				
DC reactor		Built-in				

*1. Capacity is calculated at 600V for the 600V(575V) class.

*2. Indicates rated output current setting when the PWM carrier frequency (parameter F300) is 2.5 kHz.

*3. When the input voltage is below rating, the output current may be restricted or increased depending on application.

*4. Required power supply capacity varies with the value of the power supply side inverter impedance (including those of the input reactor and wires).

*5. These acoustic noise values are not guaranteed because they are just reference values.

<690 V class: ND rating>

Item		Specification								
Voltage class		690V class								
Frame size		A1Y								
Applicable motor (kW)		3	4	5.5	7.5	11	15	18.5	22	30
Rating	Type	VFAS3-								
	Form	6022PC	6030PC	6040PC	6055PC	6075PC	6110PC	6150PC	6185PC	6220PC
	Output capacity (kVA) ^{*1}	5.0	6.5	8.6	11	16	22	29	35	41
	Output current (A) ^{*2}	4.2	5.4	7.2	9.5	13.5	18	24	29	34
	Output voltage	Three-phase 500V to 690V (The maximum output voltage is equal to the input supply voltage.)								
	Overload current rating	120%-1 minute								
Electrical braking	Dynamic braking circuit	Built-in								
	Dynamic braking resistor	External braking resistor (Optional)								
Power supply	Voltage-frequency	3-phase 500 V to 690 V - 50/60 Hz								
	Allowable fluctuation	Voltage 425V to 759V ^{*3} , Frequency $\pm 5\%$								
	Required power supply capacity (kVA) ^{*4}	6.0	7.6	10	13	18	24	29	33	41
Degree of protection (IEC60529)		IP00								
Enclosure rating (UL50)		Open								
Cooling method		Forced air-cooled								
Cooling fan noise (dB) Reference value ^{*5}		58	58	58	58	58	58	58	58	58
Color		RAL7016								
EMC filter (IEC61800-3)		Category C3 (25m or less)								
DC reactor		Built-in								

*1. Capacity is calculated at 690 V for the 690 V class.

*2. Indicates rated output current setting when the PWM carrier frequency (parameter F300) is 2.5 kHz.

*3. When the input voltage is below rating, the output current may be restricted or increased depending on application.

*4. Required power supply capacity varies with the value of the power supply side inverter impedance (including those of the input reactor and wires).

*5. These acoustic noise values are not guaranteed because they are just reference values.

Item		Specification				
Voltage class		690V class				
Frame size		A2Y				
Applicable motor (kW)		37	45	55	75	90
Rating	Type	VFAS3-				
	Form	6300PC	6370PC	6450PC	6550PC	6750PC
	Output capacity (kVA) ^{*1}	54	66	79	99	129
	Output current (A) ^{*2}	45	55	66	83	108
	Output voltage	Three-phase 500V to 690V (The maximum output voltage is equal to the input supply voltage.)				
	Overload current rating	120%-1 minute				
Electrical braking	Dynamic braking circuit	Built-in				
	Dynamic braking resistor	External braking resistor (Optional)				
Power supply	Voltage-frequency	3-phase 500 V to 690 V - 50/60 Hz				
	Allowable fluctuation	Voltage 425V to 759V ^{*3} , Frequency $\pm 5\%$				
	Required power supply capacity (kVA) ^{*4}	58	68	78	110	125
Degree of protection (IEC60529)		IP00				
Enclosure rating (UL50)		Open				
Cooling method		Forced air-cooled				
Cooling fan noise (dB) Reference value ^{*5}		56	56	56	56	56
Color		RAL7016				
EMC filter (IEC61800-3)		Category C3 (25m or less)				
DC reactor		Built-in				

*1. Capacity is calculated at 690 V for the 690 V class.

*2. Indicates rated output current setting when the PWM carrier frequency (parameter F300) is 2.5 kHz.

*3. When the input voltage is below rating, the output current may be restricted or increased depending on application.

*4. Required power supply capacity varies with the value of the power supply side inverter impedance (including those of the input reactor and wires).

*5. These acoustic noise values are not guaranteed because they are just reference values.

■ Common specification

Item	Specification
Control system	Sinusoidal PWM control
Output frequency range	Setting between 0.01 - 590 Hz. Default frequency is set to 0.01-60 Hz. Maximum frequency adjustment (30 to 590Hz)
Frequency setting resolution	Analog input: 1/2000 of the highest frequency (0.03Hz at 60Hz) ; [RR] terminal (0-10V), [II] terminal (4-20mA), [RX] terminal (0-± 10V) Operation panel input: 0.1 Hz, when using Free unit multiplication factor: 0.01 Hz (99.99 Hz or less), 0.1 Hz (100.0 Hz or more) Communication command: 0.01Hz
Frequency accuracy	Analog input: ±0.2% of the maximum output frequency (at 25±10°C bias gain fine-tunable) Digital input: ±0.01%±0.022 Hz of the output frequency
Voltage/frequency characteristics	V/f constant, variable torque, automatic torque boost, vector control, base frequency adjustment 1, 2, 3, and 4 (15 - 590 Hz), V/f 5-point arbitrary setting, torque boost adjustment (0 - 30%), start frequency adjustment (0 - 10 Hz), stop frequency adjustment (0 - 30 Hz)
Frequency setting signal	3 kΩ potentiometer (possible to connect to 1k - 10 kΩ-rated potentiometer) 0 - 10Vdc (input impedance Zin: 31.5 kΩ) -10 to +10 Vdc (Zin: 31.5 kΩ) 4 - 20 mAdc (Zin: 250 Ω)
Terminal block frequency command	The characteristic can be set arbitrarily by two-point setting. Compliant with 7 types of input; analog input ([RR], [RX], [II], [AI4], [AI5]), and pulse input ([S4], [S5])
Frequency jump	Three frequency can be set. Setting of jump frequency and width.
Upper and lower limit frequencies	Upper limit frequency: 0 to max. frequency, lower limit frequency: 0 to upper limit frequency
PWM carrier frequency	Frame size A1Y: 2.5kHz (default setting, setting range: 1.0 to 6.0 kHz) Frame size A2Y: 2.5kHz (default setting, setting range: 1.0 to 4.9 kHz)
PID control	Adjustment of proportional gain, integral time, differential time and delay filter. Multi PID and external PID control.
Torque control	Voltage command input specification: -10 - +10 Vdc
Real time clock	Current time (Year, month, date, hour, minute), Timezone, Daylight saving time, 4 working days and 20 holidays can be set by parameters.

(Continued overleaf)

(Continued)

	Item	Specification
Operation specifications	Acceleration/deceleration time	0.01 - 6000 sec. Selectable from among acceleration/deceleration. times 1, 2, 3 and 4. Automatic acceleration/deceleration function. S-pattern acceleration/deceleration 1 and 2 pattern adjustable.
	DC braking	Adjustment of braking start frequency (0 - <FH>Hz), braking (0 - 100%) and braking time (0 - 25.5 sec.). With emergency off braking function and motor shaft fix control function.
	Forward run/reverse run	Forward run with ON of the terminal [F], Reverse run with ON of the terminal [R] (Default setting). Coast stop with OFF of the terminal assigned Stad-by function. Emergency off by operation panel or terminal.
	Jog run	Jog run, if selected, allows jog operation from the operation panel Jog run operation by terminal block is possible by setting the parameters.
	Preset speed operation	By changing the combination of the terminals [S1], [S2], [S3], [S4], [S5] set frequency + 31-speed operation. Selectable between acceleration/deceleration time, torque limit and V/f by set frequency.
	Retry	Capable of restarting after a check of the power circuit elements in case the protective function is activated. Max. 10 times selectable arbitrarily. Waiting time adjustment (0 - 10 sec.)
	Soft stall	Automatic load reduction control at overloading. (Default: OFF)
	Cooling fan ON/OFF management	The cooling fan will be stopped automatically to assure long life when unnecessary.
	Lockout key operation	Key lock selectable of RUN key, HAND/AUTO key , emergency stop/reset by STOP key or all keys on operation panel, with/without password.
	Regenerative power ride-through control	Possible to keep the motor running using its regenerative energy in case of a momentary power failure. (Default: OFF)
	Auto-restart	Possible to restart the motor in coasting in accordance with its speed and direction. (Default: OFF)
	Simplified pattern operation	Possible to select each 8 patterns in 2 groups from 15-speed operation frequency. Max. 16 types of operation possible. Terminal operation/repeat operation possible.
	Commercial power supply/ Inverter switching	Possible to switch operation by commercial power supply or inverter
	Light-load high-speed operation	Improves the efficiency of the machine by increasing the motor speed when it is running under light load.
	Droop function	When two or more inverters are used to operate a single load, this function prevents load from concentrating on one inverter due to unbalance.
Override function	External input signal adjustment is possible to the frequency command value.	
Protective function	Protective function	Stall prevention, current limit, overcurrent, overvoltage, short circuit on the load side, ground fault on the load side *1, undervoltage, momentary power failure (15 ms or more), non-stop control at momentary power failure, overload protection, arm short-circuit at starting, overcurrent on the load side at starting, overcurrent and overload at braking resistor, overheat, emergency off
	Electronic thermal characteristic	Switchable between standard motor/constant torque motor, adjustment of overload protection and stall prevention level.
	Reset	Reset by 1a contact closed (or 1b contact opened), or by operation panel. Or power supply OFF/ON. This function is also used to save and clear trip records.

(Continued overleaf)

(Continued)

Item		Specification	
Display function	Display	Alarms	Stall prevention during run, overvoltage limit, overload, undervoltage on power supply side, DC circuit undervoltage, setting error, in retry, upper limit, lower limit. (Control power supply option undervoltage), (Operation panel disconnection).
		Causes of fault	Overcurrent, overvoltage, overheat, short circuit on the load side, ground fault on the load side, inverter overload, arm short-circuit at starting, overcurrent on the load side at starting, cooling fan fault, CPU fault, EEPROM fault, RAM fault, ROM fault, communication error, (braking resistor overcurrent/overload), (emergency off), (undervoltage), (undercurrent), (overtorque), (motor overload), (input phase lost), (output phase lost) The items in the parentheses are selectable.
		Monitoring function	Output frequency, frequency command, forward run/reverse run, output current, DC voltage, output voltage, compensated frequency, terminal input/output information, CPU version, past trip history, cumulative operation time, feedback frequency, torque, torque command, torque current, exiting current, PID feedback value, motor overload factor, inverter overload factor, PBR overload factor, PBR load factor, input power, output power, peak output current, peak DC voltage, RR input, II input, RX input, AI4 input, AI5 input, FM output, AM output, expansion I/O card option CPU version, integral input power, integral output power, communication option reception counter, communication option abnormal counter.
		Free unit display	Display of optional units other than output frequency (motor speed, line speed, etc.), current ampere/% switch, voltage volt/% switch
		Automatic edit function	Searches automatically parameters that are different from the default setting parameters. Easy to find changed parameters.
	User default setting	User parameter settings can be saved as default settings. Allows to restore the parameters to the user-defined parameter settings.	
LED	Charge lamp	Indicates power circuit capacitor charging.	

(Continued overleaf)

(Continued)

Item	Specification
Digital input	14 digital input terminals (of which 6 are optional) are programmable digital input, and the signal function are arbitrarily selected from 188 types including positive/negative logic selection. 3 function can be assigned for some terminals. The input level complies with IEC61131-2 logic type1.
Digital output	3 digital output terminals (of which 2 are optional) are programmable digital output, and the signal function are arbitrarily selected from 260 types including positive/negative logic selection. 2 function can be assigned for some terminals. Output capacity is 24Vdc, 50mA.
Sink/Source logic setting	Possible to select minus common (CC) or plus common (P24) for digital inputs by mechanical switch. (Default setting: external power supply: PLC)
Pulse train frequency input	Possible to be assigned on digital input ([S4] and [S5]) terminals (Up to 30 kpps), can be used as PG input
Pulse train frequency output	Possible to be assigned on digital output [FP] terminal (Up to 30 kpps, duty 50%)
Relay output (Fault detection relay)	1c contact and five 1a contacts (of which 3 are optional) relays are programmable output, and the signal function are arbitrarily selected from 260 types. Output capacity is 250Vac-2A or 30Vdc-2A at maximum. (Fault detection output is assigned on 1c contact relay at default setting)
Frequency command input	5 analog input terminals (of which 2 are optional) are frequency command input, The input level depends on each terminal (0-10V, +/-10V, 0-20/4-20mA or PTC).
Output for frequency meter/ Output for ammeter	2 analog output terminals are programmable analog output, and the signal function are arbitrarily selected from 67 types. The output level are also programmable (1mA dc full-scale milli-ammeter, 0-20mA, 4-20mA or 0-10V).
Control power supply	2 output: 10V-10mA and 24V-200mA with current limiter 1 input: control supply back up function (24Vdc-1A)
Functional Safety	Safe Torque Off comply with IEC61800-5-2
Communication function	Embedded Ethernet (dual port with switch): EtherNet/IP™, Modbus TCP, Webserver Embedded RS485 (2 channel): Toshiba inverter protocol, Modbus RTU Optional: PROFINET, DeviceNet®, PROFIBUS DP, EtherCAT®, CANopen®
Use environments	Indoors (free from direct sunlight, corrosive gas, explosive gas, flammable gas, oil mist, metal powder, and non-conductive or conductive dust etc.)
Ambient temperature	-15 to +60°C (Derating of rated current is needed when ambient temperature will rise above 50°C) ^{*2}
Storage temperature	-25 to +70°C (temperature applicable for a short term)
Relative humidity	5 to 95% (free from condensation)
Altitude	Drive operating altitude is less or equal to 2,000m with TT/TN/IT system. The drive can be operated 2,000m with an isolated transformer to pass an overvoltage category II and limited to 4,800m with TT/TN/IT system. Cannot be connected to the corner-earthed system Current reduction necessary if above 1000m ^{*3}
Vibration ^{*4}	5.9 m/s ² {0.6G} or less (10 - 55 Hz)

*1: This function protects inverters from overcurrent due to output circuit ground fault.

*2: For detail of current reduction, refer to [2. 1. 2].

*3: Current must be reduced by 1% for each 100m over 1000m. (e.g. 90% at 2000m, 80% at 3000m.)

*4: Test condition: IEC60068-2-6, IEC60068-2-27

6.2 Outside dimensions and mass

■ Outside dimensions and mass

Frame size	Type-Form	Dimensions (mm)					Approximate mass (kg)
		W	H	D	W1	H1	
A1Y	VFAS3-6022PC	240	420	242	206	403	21.6
	VFAS3-6030PC						
	VFAS3-6040PC						
	VFAS3-6055PC						
	VFAS3-6075PC						
	VFAS3-6110PC						
	VFAS3-6150PC						
	VFAS3-6185PC						
VFAS3-6220PC							
A2Y	VFAS3-6300PC	320	630	297	280	604.5	51.9
	VFAS3-6370PC						
	VFAS3-6450PC						
	VFAS3-6550PC						
	VFAS3-6750PC						
							52.5

With NEMA Type 1 kit

Frame size	Type-Form	Dimensions (mm)					Approximate mass (kg)
		W	H	D	W1	H1	
A1Y	VFAS3-6022PC	240	553	242	206	403	24
	VFAS3-6030PC						
	VFAS3-6040PC						
	VFAS3-6055PC						
	VFAS3-6075PC						
	VFAS3-6110PC						
	VFAS3-6150PC						
	VFAS3-6185PC						
VFAS3-6220PC							
A2Y	VFAS3-6300PC	320	808	297	280	604.5	56.5
	VFAS3-6370PC						
	VFAS3-6450PC						
	VFAS3-6550PC						
	VFAS3-6750PC						
							57

■ Outline drawing

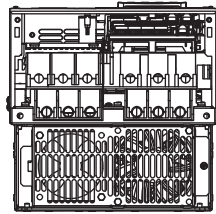
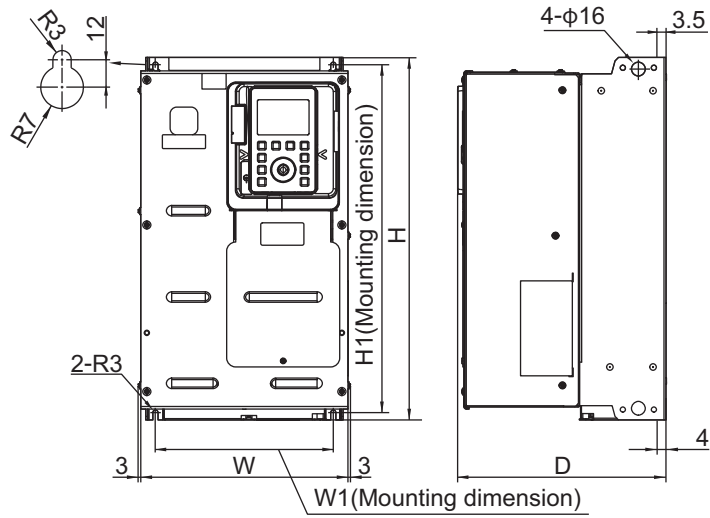

Frame size A1Y

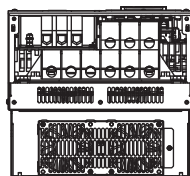
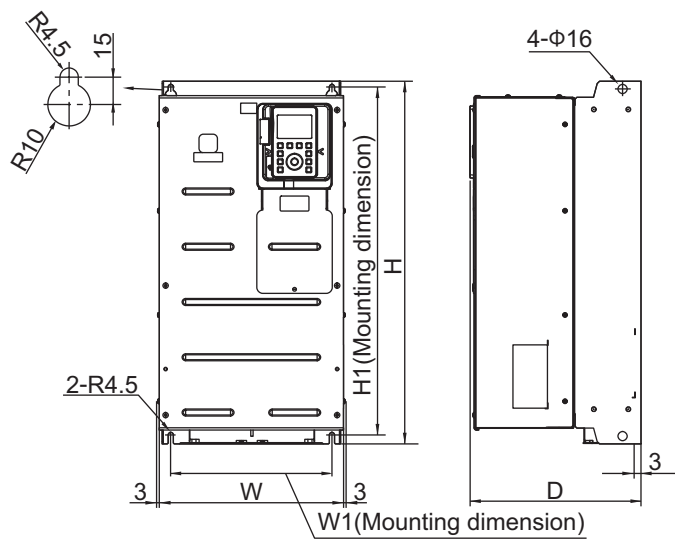

Frame size A2Y

7 | Warranty

I

II

7.1 Warranty period

1

This product's warranty period is 12 months after the purchase, or 18 months from the date of manufacture printed on the rating plate, whichever precedes the other.

2

The warranty period of repaired products will not exceed the warranty period before the repair takes place.

3

7.2 Scope of warranty

4

If a product failure is found during the warranty period due to our negligence, please return the product to Toshiba distributor of purchase, for a replacement or repair of the defective component.

5

The warranty shall only cover the purchased or delivered product itself.

6

The following circumstances will incur paid service even before the warranty period expires.

- Product replacement or repair when the product is not returned
- Product failure or damage due to misuse, inappropriate repair or modification of the product.
- Product failure or damage for reasons such as but not limited to a fall after purchase, an accident during transport, or handling (e.g. smoking) during transport
- Product failure or damage by natural disasters or unforeseeable external causes such as but not limited to fire, salt exposure, gas exposure, earthquakes, storms, floods, lightning and abnormal voltage
- Product failure or damage by use under inappropriate circumstances, environments or use not suggested in the product catalog or instruction manual, or use not complying with the original use intended for the product
- Product failure or damage by the lack of proper maintenance or replacement of expiring parts suggested in the instruction manual
- In case the product is embedded in your equipment, product failure or damage by causes irrelevant to the product, such as the design of your equipment and software
- In case the product is embedded in your equipment, product failure that could have been avoided if your equipment had featured a safety device in compliance with the law that governs your equipment, or any feature or structure that is considered the norm by the industry standard
- Any product failure or damage by accidents that were unforeseeable with the technological standard at shipment

7

8

7.3 Warranty exemptions

Irrespective of the warranty period, the warranty shall not cover the following conditions.

- Compensation for any damage not attributed to our negligence
- Compensation for any loss of business opportunity or income caused by failure of the product
- All liabilities and compensations for any damage, secondary damage, accidents, damage to any entity that is not the product and damage to any other operations that arise from special circumstances, that we may or may not foresee
- Any compensations for the results of your product replacement, readjustment of the local equipment after replacement, launch test, inspections, or any other operations

7.4 Service after the end of production

Please ask Toshiba distributor of purchase about the stop of production and repair work for each product.

8 | Others

I

II

1

2

3

4

5

6

7

8

Regarding others information, refer to “VF-AS3 instruction manual” (E6582062).

[I. Safety precautions]

[II. Introduction]

[1. 3 Indication of product type]

[1. 4 Structure of equipment]

[1. 5 Operation procedure]

[2. 3. 5 Control terminals]

[2. 3. 6 RS485 communication ports]

[2. 3. 7 Ethernet ports]

[3. [Basic operation] Operation panel and screen display]

[4. [Basic operation] Operation methods of motor]

[5. [Fundamental operation] How to use parameters]

[6. [Advanced] How to use parameters]

[7. Operating using external signals]

[8. Monitoring the inverter status in operation / before tripping]

[13. Trip information and measures]

[14. Maintenance and inspection]

Exception of cooling fan inspection.

14.2.2 Periodical inspection on the replacement parts

■ Cooling fan inspection

The design life expectancies of the cooling fans that cool down the heat-generating parts are as follows:

VFAS3-6022PC to 6750PC: Design life expectancy 8 years

[16. Disposal]

TOSHIBA

Toshiba Industrial Products and Systems Corporation

Motor Drive Division
72-34, Horikawa-cho, Saiwai-Ku, Kawasaki, Kanagawa
212-8585, Japan
TEL: +81-44-520-0828
FAX: +81-44-520-0508

<https://www.toshiba-tips.co.jp/en/>

Toshiba International Corporation
13131 West Little York RD., Houston
TX 77041, U.S.A
TEL: +1-713-466-0277
FAX: +1-713-896-5242

Toshiba International Corporation Pty Ltd
11A Gibbon Road, Winston Hills, Sydney,
NSW 2153, Australia
EMAIL: sales@tic.toshiba.com.au
TEL: +61-2-8867-6200
FAX: +61-2-9624-7104

Toshiba Industrial Products Asia Co., Ltd.
Plot No.309, Road No.9, Amata Industrial Park,
Long Binh Ward, Dong Nai, Vietnam
TEL: +84-251-3936969
FAX: +84-251-3936847

AUTHORIZED DISTRIBUTOR WITHIN EUROPEAN UNION AND UNITED KINGDOM

TECNO BI SRL

Via Casiglie Strada Bassa 19, 41049 Sassuolo (MO) Italy
<https://www.tecnobi.it/>
EMAIL: info@tecnobi.it
TEL: +39-0536-921209 / FAX: +39-0536-921315

esco antriebstechnik gmbh

Biberweg 10, D-53842 Troisdorf, Germany
<https://www.esco-antriebstechnik.de/>
EMAIL: info@esco-antriebstechnik.com
TEL: +49- (0) 2241-4807-0 / FAX: +49- (0) 2241-4807-10

CT Automatismos Y Procesos, S.L.

Avda. Conflent 66,08915 Badalona, Spain
<https://www.ctautomatismos.com/>
EMAIL: automatismos@ctautomatismos.com
TEL: +34-93-395-29-07

PES Group Ltd.

17 Handley Page Way, St Albans AL2 2 DQ, United Kingdom
<https://www.pes-group.co.uk/>
EMAIL: info@pes-group.co.uk
TEL: +44- (0) -1923-853434